

Q5X Laser Measurement Sensor with IO-Link

Instruction Manual

Original Instructions
208794 Rev. E
16 March 2021
© Banner Engineering Corp. All rights reserved



208794

Contents

1 Product Description	4
1.1 Models	4
1.2 Overview	4
1.3 Class 2 Laser Description and Safety Information	4
1.4 Features	5
1.4.1 Display and Indicators	5
1.4.2 Buttons	6
2 Installation	7
2.1 Sensor Orientation for the Triangulation Models (Maximum Range < 5000 mm)	7
2.2 Mount the Device	7
2.3 Wiring Diagram	8
2.4 Cleaning and Maintenance	8
2.5 Connecting to RSD1	9
2.6 Button Map from RSD1 to Sensor	10
3 Sensor Programming	11
3.1 Channel 1 and Channel 2 (CH1/CH2)	11
3.2 Setup Mode	11
3.2.1 Output	14
3.2.2 TEACH Mode	14
3.2.3 Adaptive Tracking	14
3.2.4 Window Size	15
3.2.5 Response Speed	15
3.2.6 Gain and Sensitivity	16
3.2.7 Output Timing Delays	16
3.2.8 Hysteresis and	17
3.2.9 Zero Reference Location	18
3.2.10 Shift the Zero Reference Location after a TEACH	18
3.2.11 Offset	19
3.2.12 Display View	20
3.2.13 Units	20
3.2.14 Output Type Polarity	20
3.2.15 Exit Setup Mode	20
3.2.16 Reset to Factory Defaults	20
3.3 Manual Adjustments	21
3.4 Remote Input	21
3.4.1 Select the TEACH Mode Using the Remote Input	22
3.4.2 Reset to Factory Defaults Using the Remote Input	23
3.5 Locking and Unlocking the Sensor Buttons	23
3.6 TEACH Procedures	23
3.6.1 Two-Point Static Background Suppression	24
3.6.2 Dynamic Background Suppression	25
3.6.3 One-Point Window (Foreground Suppression)	26
3.6.4 One-Point Background Suppression	28
3.6.5 Dual (Intensity + Distance)	29
3.7 Pulse Frequency Modulation (PFM) Output	30
3.8 Sync Master/Slave	30
4 IO-Link Interface	32
5 Specifications	33
5.1 Specifications	33
5.2 Dimensions	35
5.3 Performance Curves	35
6 Additional Information	38
6.1 Dual (Intensity + Distance) Mode	38
6.2 Dual Mode Reference Surface Considerations	38
6.3 Dual Mode Considerations for Clear and Transparent Object Detection	38
6.4 Abbreviations	40
7 Accessories	42
7.1 Cordsets	42
7.2 Brackets	42
7.3 Reference Targets	43
7.4 RSD1 Remote Display	43
8 Product Support and Maintenance	44
8.1 Troubleshooting	44

8.2 Contact Us 44

8.3 Banner Engineering Corp. Limited Warranty 44

1 Product Description

Laser sensor with dual outputs and IO-Link



- Laser measurement sensor with a range up to 5000 mm
- Bright output indicators and real-time distance feedback provide easy set up and troubleshooting for reduced installation costs
- Exceptionally high excess gain enables the sensor to reliably detect the darkest objects (< 6% reflective black targets), including black targets against a black background, black targets against a shiny metal background, clear and reflective objects, multicolor packaging, and targets of all colors
- Dual independent output channels and communication over IO-Link
- Optional Remote Sensor Display (RSD) (available separately) enables remote programming and monitoring



WARNING:

- **Do not use this device for personnel protection**
- Using this device for personnel protection could result in serious injury or death.
- This device does not include the self-checking redundant circuitry necessary to allow its use in personnel safety applications. A device failure or malfunction can cause either an energized (on) or de-energized (off) output condition.

1.1 Models

Model	Sensing Range	Channel 1 Default	Channel 2 Default	Connection
Q5XKLAF2000-Q8	95 mm to 2000 mm (9.5 cm to 200 cm)	IO-Link, Push/pull output	PNP output or user selectable multi-function	270° rotatable Integral 4-pin M12 male quick disconnect
Q5XKLAF5000-Q8	50 mm to 5000 mm (5 cm to 500 cm)	User selectable to be fixed NPN or PNP	User selectable to be fixed NPN or PNP	

1.2 Overview

The Q5X Laser Measurement Sensor offers IO-Link and multifunction input and output.

The normal sensor state is Run mode. From Run mode, users may change the switch point value and channel selection and perform the selected TEACH method.

The secondary sensor state is Setup mode. From Setup mode, users may select the TEACH mode, adjust all standard operating parameters, and perform a factory reset.

1.3 Class 2 Laser Description and Safety Information



CAUTION:

- **Return defective units to the manufacturer.**
- Use of controls or adjustments or performance of procedures other than those specified herein may result in hazardous radiation exposure.
- Do not attempt to disassemble this sensor for repair. A defective unit must be returned to the manufacturer.



CAUTION:

- **Never stare directly into the sensor lens.**
- Laser light can damage your eyes.
- Avoid placing any mirror-like object in the beam. Never use a mirror as a retroreflective target.



For Safe Laser Use - Class 2 Lasers

- Do not stare at the laser.
- Do not point the laser at a person's eye.
- Mount open laser beam paths either above or below eye level, where practical.
- Terminate the beam emitted by the laser product at the end of its useful path.

Class 2 lasers are lasers that emit visible radiation in the wavelength range from 400 nm to 700 nm, where eye protection is normally afforded by aversion responses, including the blink reflex. This reaction may be expected to provide adequate protection under reasonably foreseeable conditions of operation, including the use of optical instruments for intrabeam viewing.

Low-power lasers are, by definition, incapable of causing eye injury within the duration of a blink (aversion response) of 0.25 seconds. They also must emit only visible wavelengths (400 to 700 nm). Therefore, an ocular hazard may exist only if individuals overcome their natural aversion to bright light and stare directly into the laser beam.

Class 2 Red Laser models with maximum range of 2000 mm: Reference IEC 60825-1:2007

Figure 1. FDA (CDRH) warning label (Class 2)



Output: < 1.0 mW

Laser wavelength: 640 to 670 nm

Pulse Duration: 20 µs to 2 ms

Class 2 Red Laser models with maximum range > 2000 mm: Reference IEC 60825-1:2014

Figure 2. FDA (CDRH) warning label (Class 2)



Output: < 1.0 mW

Laser wavelength: 640 to 670 nm

Pulse Duration for <5 m Models: 20 µs to 2 ms

Pulse Duration for ≥ 5 m Models: 3 µs

1.4 Features



1. Two output indicators (amber)
2. Display
3. Buttons

1.4.1 Display and Indicators

The display is a 4-digit, 7-segment LED. Run mode is the primary view displayed.

For 2-pt, BGS, FGS, and DYN TEACH modes, the display shows the current distance to the target in centimeters. For Dual TEACH mode, the display shows the percentage matched to the taught reference surface. A display value of **9999** indicates the sensor has not been taught.

Figure 3. Display in Run Mode

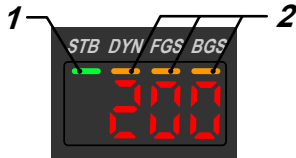

1. Stability Indicator (STB—Green)
2. Active TEACH Indicators
 - DYN—Dynamic (Amber)
 - FGS—Foreground Suppression (Amber)
 - BGS—Background Suppression (Amber)

Output Indicator

- On—Output is on
- Off—Output is off

Stability Indicator (STB)

- On—Stable signal within the specified sensing range
- Flashing—Marginal signal, the target is outside the limits of the specified sensing range, or a multiple peak condition exists
- Off—No target detected within the specified sensing range

Active TEACH Indicators (DYN, FGS, and BGS)

- DYN, FGS, and BGS all off—Two-point TEACH mode selected (default)
- DYN on—Dynamic TEACH mode selected
- FGS on—Foreground suppression TEACH mode selected
- BGS on—Background suppression TEACH mode selected
- DYN, FGS, and BGS all on—Dual TEACH mode selected

1.4.2 Buttons

Use the sensor buttons **(SELECT)(TEACH)**, **(+)(CH1/CH2)**, and **(-)(MODE)** to program the sensor.

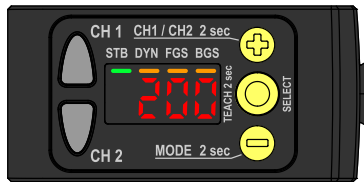

(SELECT)(TEACH)

- Press to select menu items in Setup mode
- Press and hold for longer than 2 seconds to start the currently selected TEACH mode (the default is two-point TEACH)

(+)(CH1/CH2)

- Press to navigate the sensor menu in Setup mode
- Press to change setting values; press and hold to increase numeric values
- Press and hold for longer than 2 seconds to switch between Channel 1 and Channel 2

(-)(MODE)

- Press to navigate the sensor menu in Setup mode
- Press to change setting values; press and hold to decrease numeric values
- Press and hold for longer than 2 seconds to enter Setup mode



Note: When navigating the menu, the menu items loop.

2 Installation

2.1 Sensor Orientation for the Triangulation Models (Maximum Range < 5000 mm)

Optimize detection reliability and minimum object separation performance with correct sensor-to-target orientation. To ensure reliable detection, orient the sensor as shown in relation to the target to be detected.

Figure 4. Optimal Orientation of Target to Sensor

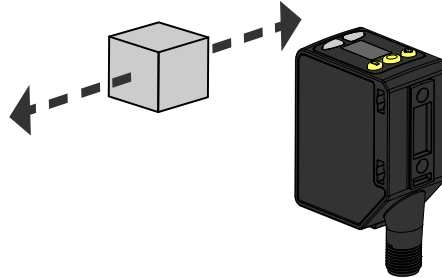

See the following figures for examples of correct and incorrect sensor-to-target orientation as certain placements may pose problems for sensing some targets. The Q5X can be used in the less preferred orientation and at steep angles of incidence and still provide reliable detection performance due to its high excess gain. For the minimum object separation distance required for each case, refer to [Performance Curves](#) on p. 35.

Figure 5. Orientation by a wall

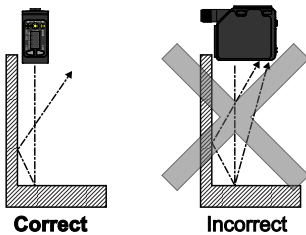

Figure 6. Orientation for a moving object

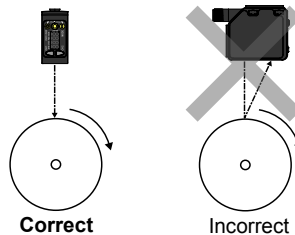

Figure 7. Orientation for a height difference

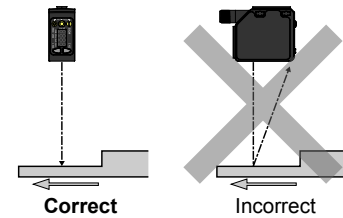

Figure 8. Orientation for a color or luster difference

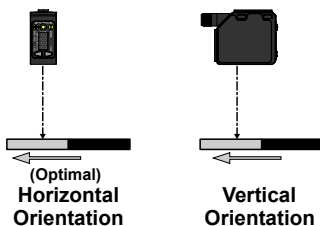
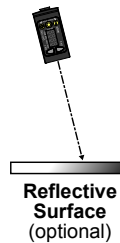

Figure 9. Orientation for highly reflective target ¹



2.2 Mount the Device

1. If a bracket is needed, mount the device onto the bracket.
2. Mount the device (or the device and the bracket) to the machine or equipment at the desired location. Do not tighten the mounting screws at this time.
3. Check the device alignment.
4. Tighten the mounting screws to secure the device (or the device and the bracket) in the aligned position.

¹ Applying tilt to sensor may improve performance on reflective targets. The direction and magnitude of the tilt depends on the application, but a 15° tilt is often sufficient.

2.3 Wiring Diagram

Figure 10. Channel 2 as PNP Discrete or PFM Output

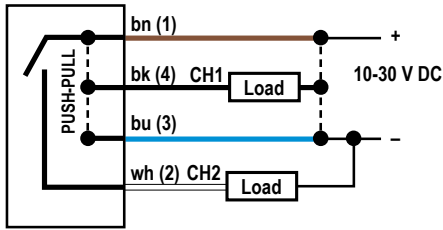
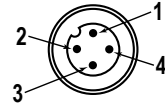
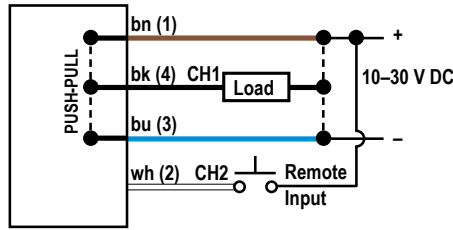

Figure 11. Channel 2 as Remote Input



Note: Open lead wires must be connected to a terminal block.



Note: The Channel 2 wire function and polarity is user-selectable. The default for the wire is PNP output.

NPN Discrete Outputs

Figure 12. Channel 1 = NPN Output, Channel 2 = NPN Output

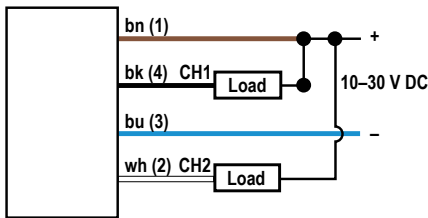

PNP Discrete Outputs

Figure 13. Channel 1 = PNP Output, Channel 2 = PNP Output

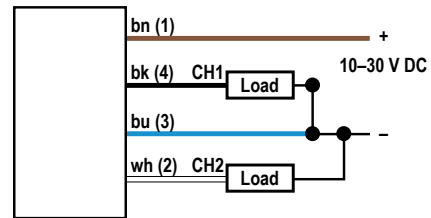

NPN Output and Remote Input

Figure 14. Channel 1 = NPN Output, Channel 2 = NPN Remote Input

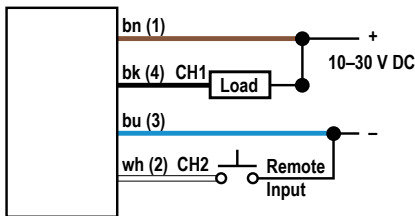

PNP Output and Remote Input

Figure 15. Channel 1 = PNP Output, Channel 2 = PNP Remote Input

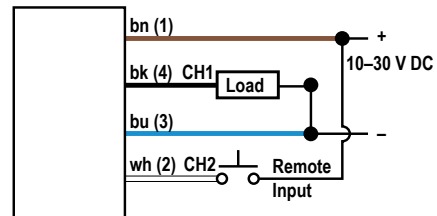

2.4 Cleaning and Maintenance

Handle the sensor with care during installation and operation. Sensor windows soiled by fingerprints, dust, water, oil, etc. may create stray light that may degrade the peak performance of the sensor. Blow the window clear using filtered, compressed air, then clean as necessary using only water and a lint-free cloth.

2.5 Connecting to RSD1

The following diagram depicts the connection of the Q5X to the optional RSD1 accessory.

Figure 16. Q5X to RSD1

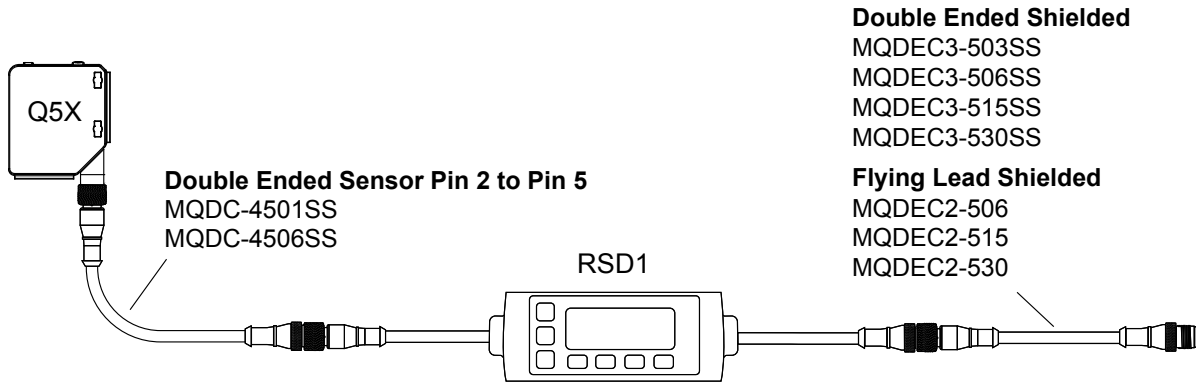

Use these cordsets to connect the RSD1 to the Q5X sensor.

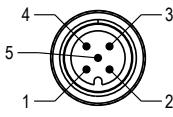
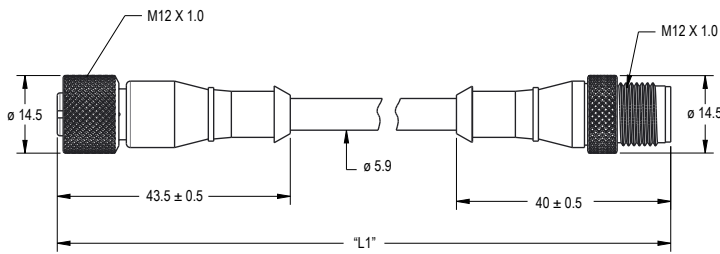
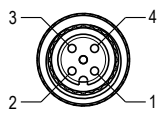
4-Pin Female and 5-Pin Male Threaded M12/Euro-Style Cordset—Double Ended			
Model	Length "L1"	Style	Pinout
MQDC-4501SS	0.30 m (0.98 ft)	Female Straight/ Male Straight	<p>Male</p>  <p>1 = Brown 2 = Not Used 3 = Blue 4 = Black 5 = White</p>
MQDC-4506SS	1.83 m (6.00 ft)		
			<p>Female</p>  <p>1 = Brown 2 = White 3 = Blue 4 = Black</p>

Use these cordsets to connect the RSD1 to any PLC or IO block.

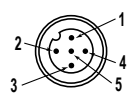
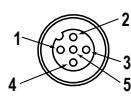
5-Pin Male Threaded and 5-Pin Female Quick Disconnect M12 Cordset with Shield—Double Ended				
Model	Length "L1"	Style	Pinout (Male)	Pinout (Female)
MQDEC3-503SS	0.91 m (2.99 ft)	Female Straight/Male Straight		
MQDEC3-506SS	1.83 m (6 ft)			
MQDEC3-515SS	4.58 m (15 ft)			
MQDEC3-530SS	9.2 m (30.2 ft)			

5-Pin Male Threaded and 5-Pin Female Quick Disconnect M12 Cordset with Shield—Double Ended				
Model	Length "L1"	Style	Pinout (Male)	Pinout (Female)
			1 = Brown 2 = White 3 = Blue	4 = Black 5 = Gray

5-Pin Threaded M12 Cordsets with Shield—Single Ended				
Model	Length	Style	Dimensions	Pinout (Female)
MQDEC2-506	2 m (6.56 ft)	Straight		<p>1 = Brown 2 = White 3 = Blue 4 = Black 5 = Gray</p>
MQDEC2-515	5 m (16.4 ft)			
MQDEC2-530	9 m (29.5 ft)			
MQDEC2-550	15 m (49.2 ft)	Right-Angle		
MQDEC2-506RA	2 m (6.56 ft)			
MQDEC2-515RA	5 m (16.4 ft)			
MQDEC2-530RA	9 m (29.5 ft)			
MQDEC2-550RA	15 m (49.2 ft)			

2.6 Button Map from RSD1 to Sensor

Refer to this table for the RSD1 button association with your sensor.

Device	Up Button	Down Button	Enter Button	Escape Button
RSD1				
Q4X and Q5X				N/A

3 Sensor Programming

Program the sensor using the buttons on the sensor or the remote input (limited programming options).

In addition to programming the sensor, use the remote input to disable the buttons for security, preventing unauthorized or accidental programming changes. See [Locking and Unlocking the Sensor Buttons](#) on p. 23 for more information.

3.1 Channel 1 and Channel 2 (CH1/CH2)

Press CH1/CH2 button to switch between Channel 1 and Channel 2. Within each channel there are options specific to that channel. For settings that are common to both channels, the menus are only available in Channel 1. The default is Channel 1.

To switch between Channel 1 and Channel 2:

1. Press and hold **CH1/CH2** for longer than 2 seconds. The current selection displays.
2. Press **CH1/CH2** again. The new selection flashes slowly.
3. Press **SELECT** to change the Channel and return to Run mode.



Note: If neither **SELECT** nor **CH1/CH2** are pressed after step 2, the new selection flashes slowly for a few seconds, then flashes quickly and the sensor automatically changes the Channel and returns to Run mode.

3.2 Setup Mode

Access Setup mode and the sensor menu from Run mode by pressing and holding **MODE** for longer than 2 seconds. Use

+ and **-** to navigate through the menu. Press **SELECT** to select a menu option and access the submenus. Use **+** and **-** to navigate through the submenus. Press **SELECT** to select a submenu option and return to the top menu, or press and hold **SELECT** for longer than 2 seconds to select a submenu option and return immediately to Run mode.

To exit Setup mode and return to Run mode, navigate to **End** and press **SELECT**.



Note: The number that follows a menu option, for example **Ch1**, indicates the channel that is selected. For menu items without a number (excluding submenu items), these menu options are only available from Channel 1 and the settings apply to both channels.

Figure 17. Sensor Menu Map—Channel 1

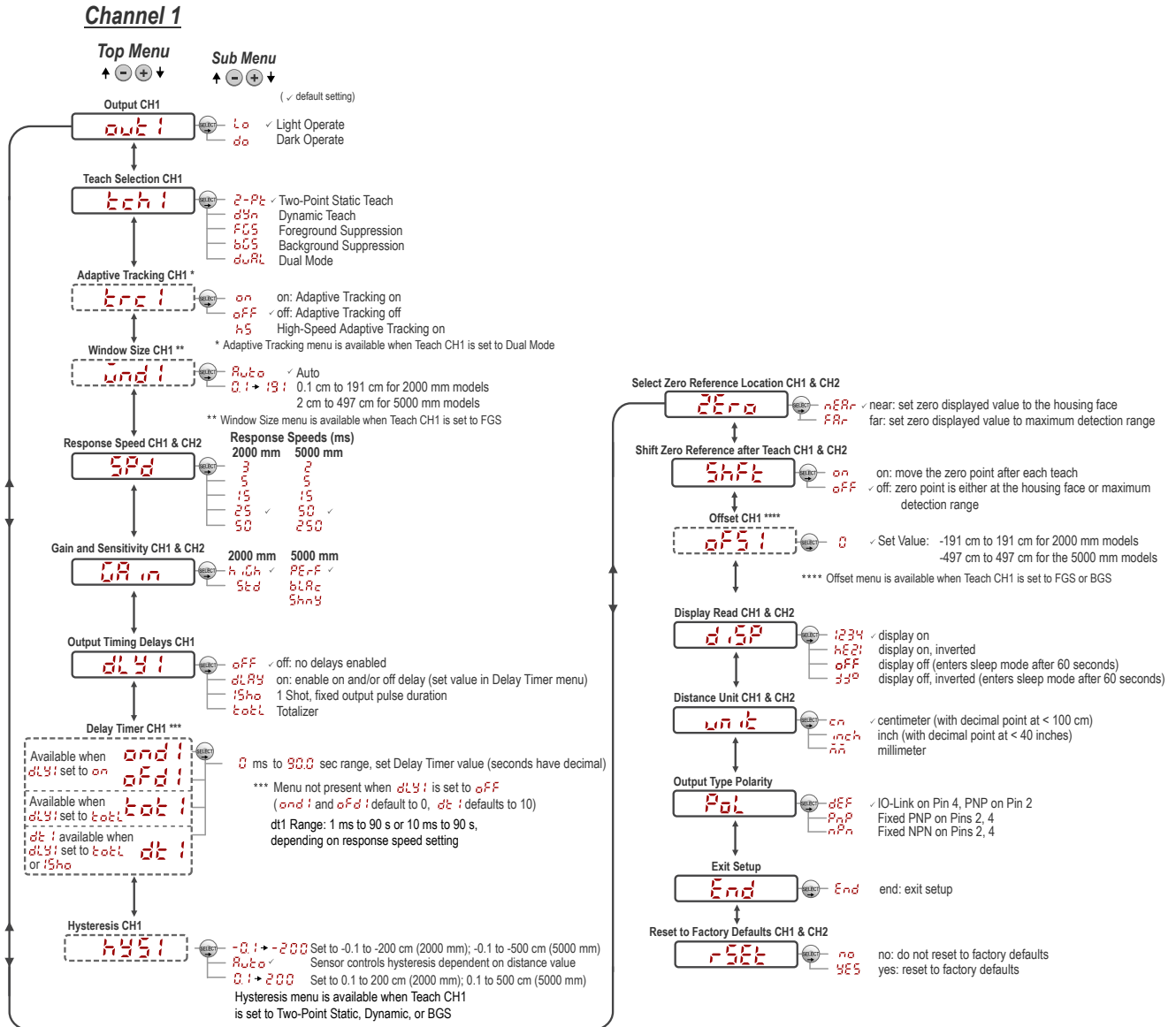
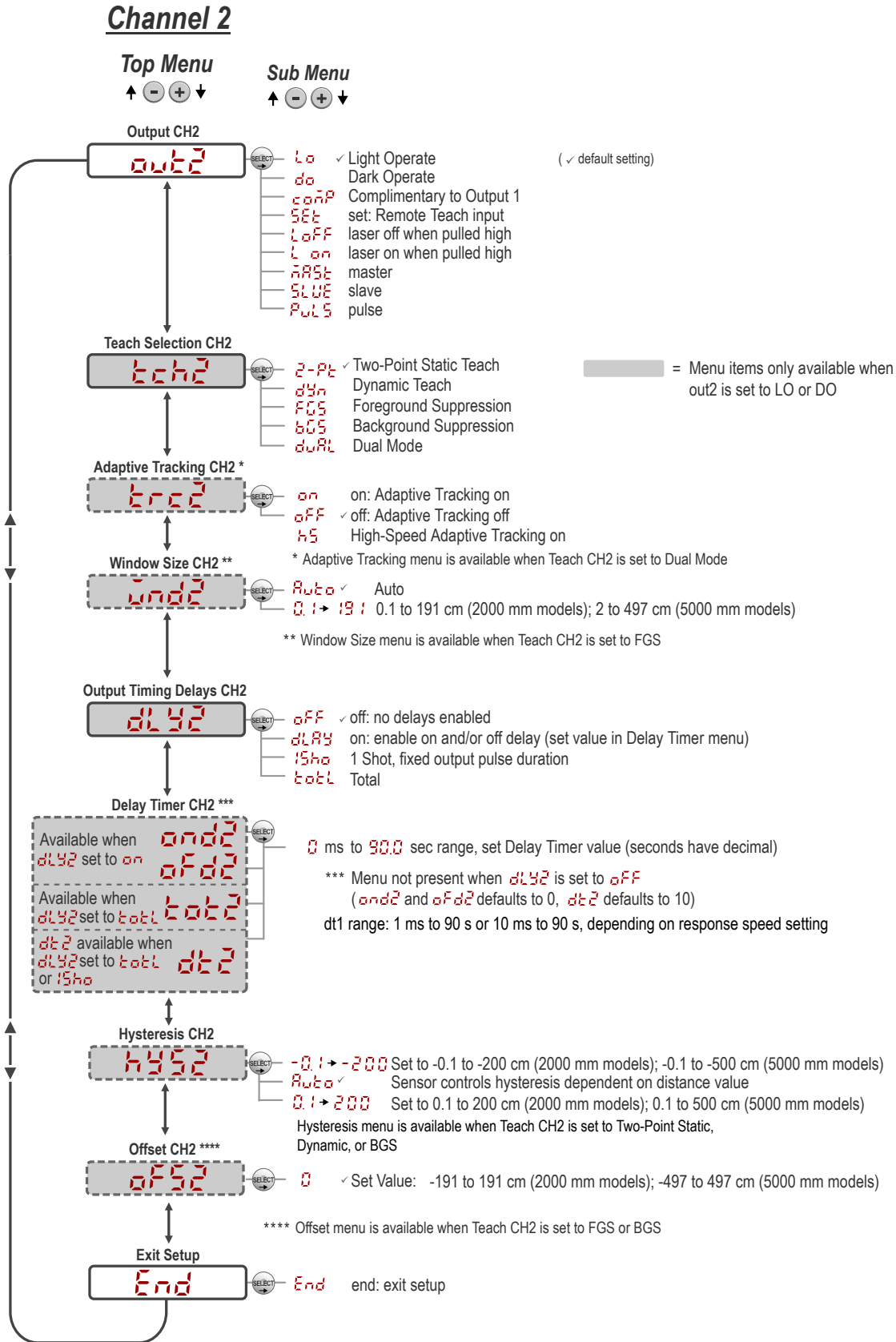

Figure 18. Sensor Menu Map—Channel 2



3.2.1 Output *out 1 out 2*



Note: The number that follows **out** on the display indicates which channel is selected.

The Output 1 menu is available in Channel 1. Use this menu to select light operate (LO) or dark operate (DO). The default output configuration is light operate. To switch between light operate and dark operate, select the desired menu option.

- *lo* —Light operate
- *do* —Dark operate

The Output 2 menu is available in Channel 2. Use this menu to set the output configuration for Channel 2. The default is light operate.

- *lo* —Light operate
- *do* —Dark operate
- *comp* —Complementary to output 1
- *set* —Remote TEACH input
- *loff* —Laser off when pulled high
- *lon* —Laser on when pulled high
- *master* —Master sync line output for two-sensor cross-talk avoidance
- *slave* —Slave sync line output for two-sensor cross-talk avoidance
- *puls* —Pulse Frequency Modulation (PFM) output (see [Pulse Frequency Modulation \(PFM\) Output](#) on p. 30)

To configure the sensor for master-slave operation, see [Sync Master/Slave](#) on p. 30.

3.2.2 TEACH Mode *tch 1 tch 2*

Use this menu to select the TEACH mode. The default is two-point TEACH. For Channel 2, this menu is available when the output is set to light operate or dark operate.



Note: The number that follows **tch** on the display indicates which channel is selected.

- *2-pt* —Two-point static background suppression
- *dyn* —Dynamic background suppression
- *fgs* —One-point window (foreground suppression)
- *bgs* —One-point background suppression
- *dual* —Dual (intensity + distance) window

After the TEACH mode is selected, from Run mode, press and hold **TEACH** for longer than 2 seconds to start the TEACH mode and program the sensor. See [TEACH Procedures](#) on p. 23 for additional information and remote input TEACH instructions.

3.2.3 Adaptive Tracking *trc 1 trc 2*

In adaptive tracking mode, the laser intensity changes to compensate for a loss in excess gain - normally caused by a dirty lens.

When operating in dual mode, the Adaptive Tracking Algorithm adjusts the switching thresholds (distance and intensity) around a taught reference surface. Adaptive tracking adjusts for small variations in the reference surface to maintain a consistent 100P (100%) on the display and to ensure reliable detection. The Adaptive Tracking menu is only available when Teach Ch1 is set to Dual Mode

Adjustment of the thresholds only occurs when the reference surface is visible to the sensor (that is, no target is present). The Adaptive Tracking Algorithm can reduce or eliminate the need to periodically re-teach the sensor as environmental conditions change around the sensor.

Enable or disable the Adaptive Tracking Algorithm from the sensor menu. The appropriate speed depends on the application. This menu is available only if dual (intensity + distance) mode is selected. For Channel 2, the output must be set to light operate or dark operate.



Note: The number that follows **trc** on the display indicates which channel is selected.

- **HS** —High-Speed Adaptive Tracking On
- **on** —Adaptive Tracking On
- **off** —Adaptive Tracking Off (default)

OFF disables the Adaptive Tracking Algorithm—Prevents the sensor from adjusting the thresholds around the taught reference surface while the sensor is in dual mode. The sensor will not adapt to or learn any target. Environmental changes may cause the displayed value to deviate from 100P (100%) over time. A periodic re-teach of the reference surface may be required to restore the displayed value to 100P if this is important to the application.

There are some cases in which disabling adaptive tracking is useful. For example, disable adaptive tracking if the target passes very slowly through the sensing beam, if the target might stop while partially blocking the beam, and if the environmental conditions are stable.

ON enables the Adaptive Tracking Algorithm at the standard speed—Recommended for many applications detecting low contrast targets. Standard adaptive tracking adjusts the thresholds around slowly changing background and environmental conditions. It adjusts the sensor for stable detection when the environment changes due to gradual dust accumulation, machine vibration, or ambient temperature changes which influence the signal from the reference surface. Standard adaptive tracking will not easily adapt to or learn slow moving, low contrast targets (for example, clear targets entering and exiting the beam over approximately 2 seconds).

HS enables the Adaptive Tracking Algorithm at high speed—Optional adaptive tracking setting used with dual mode. Use high speed adaptive tracking when the signal from the reference surface changes quickly due to unstable environmental conditions and high contrast and high-speed targets are being detected. High speed adaptive tracking adjusts the sensor for stable detection in challenging environmental conditions such as dust accumulation, machine vibration, ambient temperature changes, or a non-stable reference surface (for example, a running belt or web which influences the signal from the reference surface). For example, if the signal from the reference surface changes by 10% due to environmental effects, high speed adaptive tracking adjusts the displayed value back to 100P (100%) over 2 to 3 seconds.

High speed adaptive tracking addresses certain applications where the reference surface is not stable, but the sensor must detect high speed and high contrast targets reliably. With high speed adaptive tracking there is the potential for the sensor to adapt the thresholds to slow moving or low contrast targets, leading to missed detection events. If the detection events are generating small signal changes of similar magnitude to the background changes, detection problems are likely. Stabilize the reference surface to avoid this problem.

3.2.4 Window Size **Window**

Use this menu to manually set a window size for subsequent TEACH operations. This menu is available only if one-point window (foreground suppression) mode is selected. The default selection is Auto, where the foreground suppression (FGS) window size is automatically calculated.

This setting is automatically applied during any subsequent teach operation. The window size value represents a \pm cm value, so the total window size is twice this value. For example, a window set of 10 cm gives a 20 cm window centered around the taught point. The window size can also be changed directly from Run mode after changing the setting to any value except Auto. For Channel 2, the output must be set to light operate or dark operate.

Values:

2000 mm models: 0.1 cm to 191 cm
5000 mm models: 2 cm to 497 cm

3.2.5 Response Speed **SPD**

Use this menu to select the response speed.

Default:

2000 mm models: 25 ms
5000 mm models: 50 ms

Table 1: 2000 mm Models

Response Speed	Response Speed in Sync Mode	Repeatability	Ambient Light Rejection	Excess Gain
3 ms	6 ms	1000 μ s	Disabled	See Excess Gain in Specifications on p. 33
5 ms	10 ms	1600 μ s	Enabled	
15 ms	30 ms	3 ms	Enabled	
25 ms	50 ms	5 ms	Enabled	
50 ms	100 ms	10 ms	Enabled	

Table 2: 5000 mm Models

Response Speed	Response Speed in Sync Mode	Excess Gain
2 ms	4 ms	See Excess Gain in Specifications on p. 33
5 ms	10 ms	
15 ms	30 ms	
50 ms	100 ms	
250 ms	500 ms	

3.2.6 Gain and Sensitivity GA in

Use this menu to set the excess gain mode.

For 2000 mm models—This menu is only available when a 15, 25, or 50 millisecond response speed is selected. It is not available for 3 or 5 millisecond response speeds.

- HIGH—High excess gain mode
- Std—Standard excess gain mode with increased noise immunity

For 5000 mm models—

- PERF—Performance gain mode provides the best performance on the typical range of dark to shiny targets
- BLAc—Black gain mode provides the maximum excess gain and best performance when looking at extremely dark targets with little reflectivity
- Shny—Shiny gain mode provides the best performance when looking at extremely reflective surfaces.

3.2.7 Output Timing Delays dLY 1 dLY2

Use this menu to select the output timing delay to be set. On and off delay timers can be used together. The default is no delay. For Channel 2, this menu is available when the output is set to light operate or dark operate.



Note: The number that follows **dLY** on the display indicates which channel is selected.

- off —No delay
- dLY —Delay—enables the selection of on and off delay timers
- 1Shot —One-shot—enables a one-shot, fixed output pulse duration
- totl — Totalizer—enables an output after a defined number of targets are counted

Figure 19. Output Timing Delays

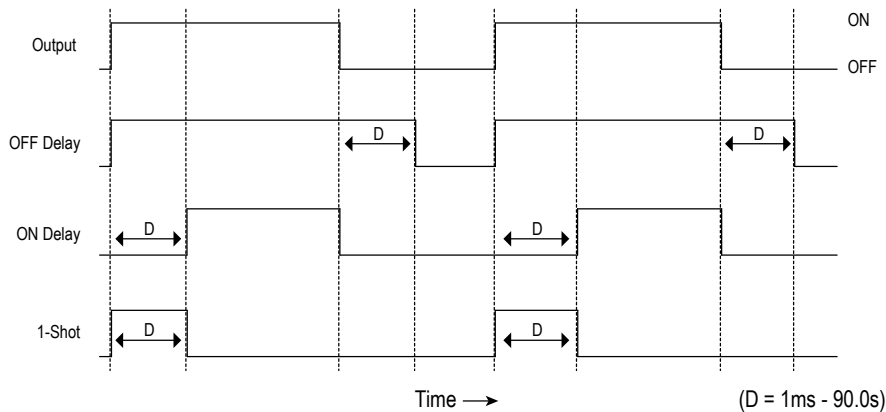

When one of the timing delay options is chosen, the sensor returns to the Setup menu and additional options become available to set the parameter(s):

dLY

- `ond` —On delay
- `ofd` —Off delay

`15ha`

- `dt1` / `dt2` —One-shot delay timer



Note: For the one-shot delay timer:

- LO = On pulse when a target is detected inside of the switch point(s)
- DO = On pulse when a target is detected outside of the switch point(s)

`totL`

- `dt1` / `dt2` —Output duration
- `tot1` / `tot2` —Number of counts before an output change

Delay Timers `ond1` `ond2` `ofd1` `ofd2` `dt1` `dt2`

Use these menus to set the delay timers. These menus are available only if an output timing delay is selected.

For `ond` and `ofd`, the default is 0.

For `dt1`, the default is 10 milliseconds for all response speeds

Use \oplus and \ominus to scroll through the values. Millisecond values do not include the decimal point; seconds values include the decimal point.

- 1 to 999 ms (when `dt1` is selected, the 1 to 9 ms range is available for 3 and 5 ms response times)
- 1.0 to 90.0 s

Totalizer `totL`

The totalizer function changes the output only after counting a designated number of targets. After selecting this function, `dt1` or `dt2` become available to define the output duration and `tot1` or `tot2` to define required number of counts before the output changes.

For `tot1` and `tot2`, the default is 1 count and the maximum is 9999 counts.

For `dt1` and `dt2`, the default is 10 milliseconds. Use \oplus and \ominus to scroll through the values. Values in millisecond do not include the decimal point; values in seconds include the decimal point.

- 1 to 999 ms (when `dt1` or `dt2` is selected, the 1 to 9 ms range is available for 1.5, 2, 3, and 5 ms response times)
- 1.0 to 90.0 s

From Run mode, press **SELECT** to change the display to show the current totalizer count. Pressing **SELECT** again changes the display back to the measured distance.

The totalizer count automatically resets after re-teaching the switch point distance or turning the sensor off.

3.2.8 Hysteresis `hys1` and `hys2`

Use this menu to set the hysteresis distance around the switch point.

- `Auto` —The sensor automatically selects a recommended minimum hysteresis distance relative to the current switch point distance,
- to `200` —Enter a user-selectable value (cm) of hysteresis distance relative to the current switch point distance.

Set Distance—The distance from the reference surface that allows stable use, including the effects of temperature and voltage, to the (standard) sensing object transit position. This is approximately 70% to 80% of the normal (rated) sensing distance.

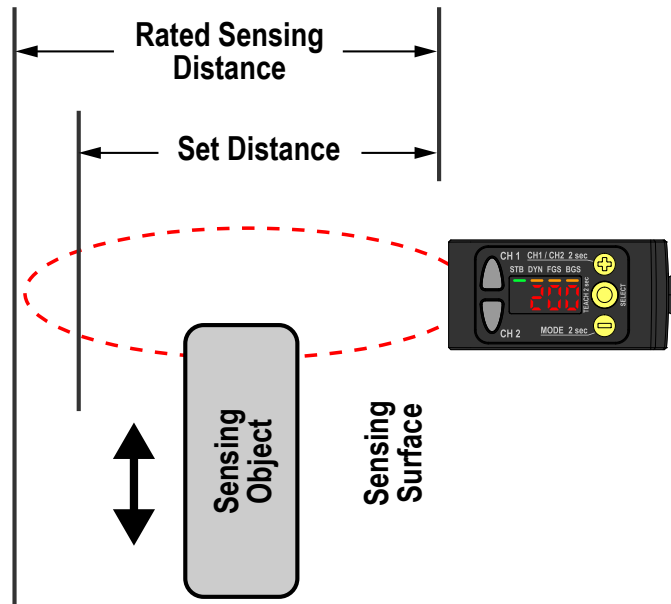

Hysteresis (Differential Travel)—With respect to the distance between the standard sensing object and the sensor, the difference between the distance at which the sensor operates and the distance at which the sensor resets.

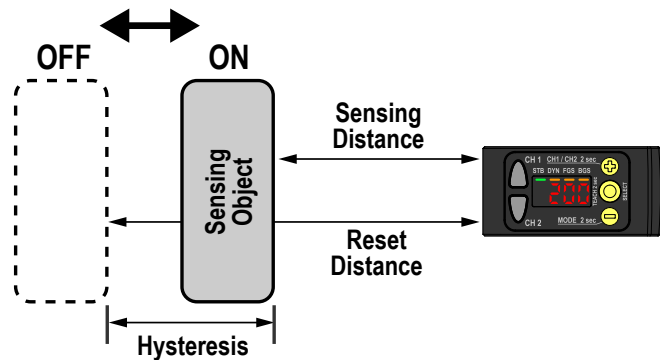

Note: Smaller hysteresis values cause the output to switch state with less differential travel. A larger hysteresis value makes the output state to remain unchanged with larger differential travel. Negative hysteresis values allow the operator to move the hysteresis to either side of the switch point.

3.2.9 Zero Reference Location **Zero**

Use this menu to select the zero reference location. Changing the zero reference location only affects the readout on the display and does not affect the output. The default is **near**, 0 = the front of the sensor. This menu is not available in dual (intensity + distance) mode.

- **near** —0 = the front of the sensor; the measurement increases further from the sensor
- **far** —0 = maximum range; the measurement increases closer to the sensor

3.2.10 Shift the Zero Reference Location after a TEACH **Shift**

Use this menu to select whether the sensor shifts the zero reference location based on the last TEACH process. The default is **off**, 0 = the front of the sensor or the maximum range. This menu is not available in dual (intensity + distance) mode.

- **on** —Shift the zero reference location to one of the taught positions with each TEACH
- **off** —0 = the front of the sensor or the maximum range, depending on the **Zero** setting

This figure illustrates three examples of how changes to the zero and shift settings affect what distance readout is shown on the display when in 2-pt TEACH mode. Changes to the zero setting affect the direction in which the distance increases. Shifting the zero reference location only affects the readout on the display and does not affect the output.

Figure 20. Example Zero and Shift settings

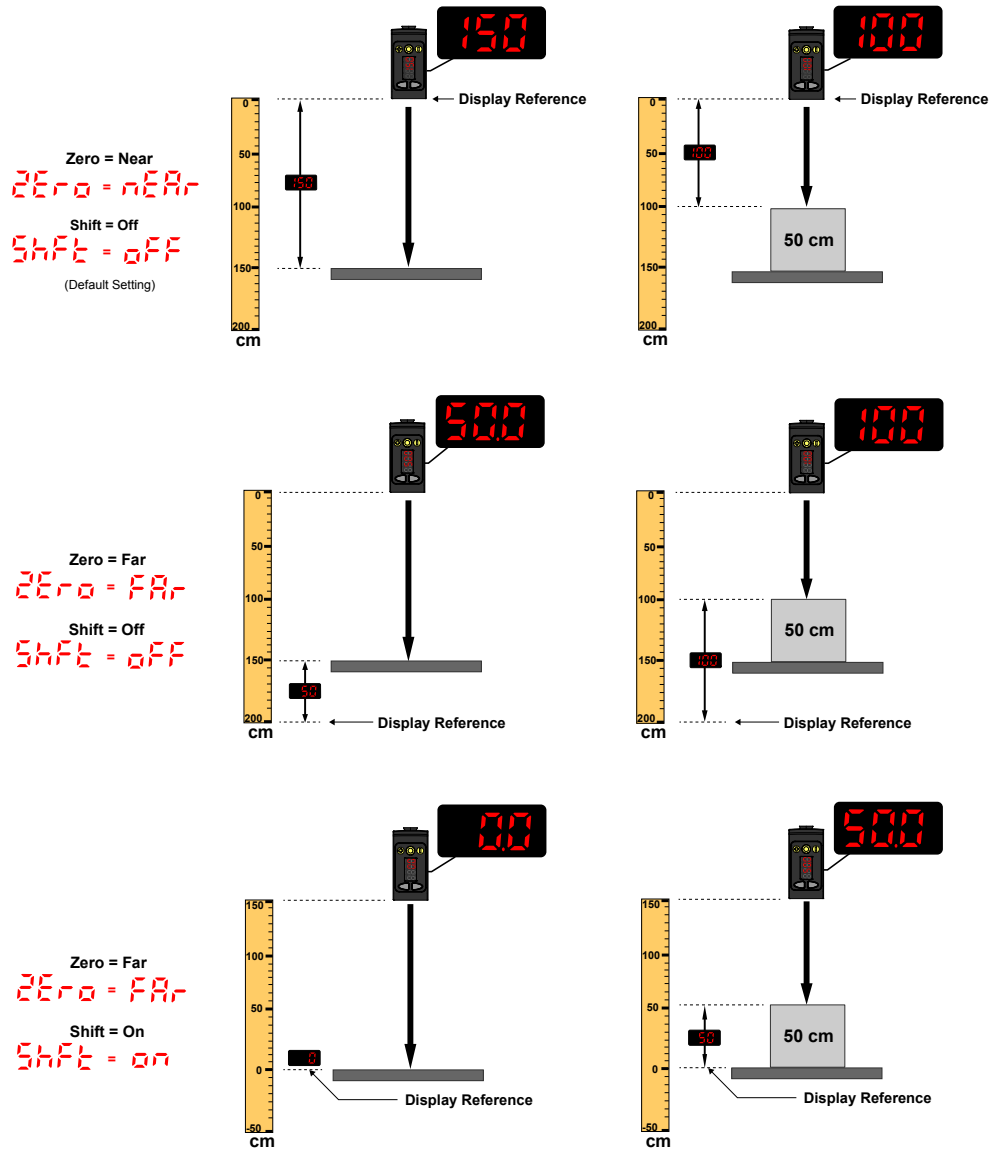

3.2.11 Offset OFS1 OFS2

Use this menu to set an offset from the taught surface during a TEACH procedure.. This menu is available only if one-point window (foreground suppression) mode or one-point background suppression mode is selected. For Channel 2, the output must be set to light operate or dark operate.



Note: The number that follows on the display indicates which channel is selected.

The offset is automatically calculated or manually defined as a consistently applied value. **Auto** is the default option. Use +/- to select a value. Values increase or decrease by up to 191 cm for 2000 mm models and up to 497 cm for 5000 mm models.

For BGS mode, the default is **Auto** because the Q5X automatically selects where to position the switch point. For FGS mode, the default is 0 because the window is centered around the taught target.

A positive offset value always shifts the switch point location or the FGS window towards the sensor.

The taught surface must be inside of the defined sensing range. When the teach mode is set to FGS, some portion of the window must be located within the sensing range. When the teach mode is set to BGS, the offset value must be within the defined sensing range. If an offset value falls outside of the sensing range, a message displays. See the applicable TEACH procedure for more information.

3.2.12 Display View *d,SP*

Use this menu to select the display view. The default is normal.

- *1234* —Normal
- *4E21* —Inverted (rotated 180°)
- *off* —Normal and the display enters sleep mode after 60 seconds
- *33°* —Inverted (rotated 180°) and the display enters sleep mode after 60 seconds

When the sensor is in sleep mode, the display wakes with the first button press.

3.2.13 Units *unit*

Use this menu to set the displayed units to centimeters (cm), inches ("), millimeters (mm).

- *cm* —centimeter (with a decimal point at < 60 centimeters)
- *inch* —inch (with a decimal point at < 24 inches)
- *mm* — millimeter

3.2.14 Output Type Polarity *Pol*

Use this menu to select the output polarity.

- *def* (Default)—Push-Pull IO-Link on pin 4 and solid state PNP on pin 2
- *PNP* —Solid state PNP on pins 2 and 4
- *nPN* —Solid state NPN on pins 2 and 4

3.2.15 Exit Setup Mode *End*

Navigate to *End* and press **SELECT** to exit Setup mode and return to Run mode.

3.2.16 Reset to Factory Defaults *rSet*

Use this menu to restore the sensor to the factory default settings.



Select *no* to return to the sensor menu without restoring the defaults. Select *yes* to apply the factory defaults and return to Run mode.





Factory Default Settings

Setting	2000 mm Model Factory Default	5000 mm Model Factory Default
Delay Timers (<i>dLY</i>)	<i>off</i> —No delay	<i>off</i> —No delay
Display View (<i>d,SP</i>)	<i>1234</i> —Normal, no sleep mode	<i>1234</i> —Normal, no sleep mode
Gain and Sensitivity (<i>GA in</i>)	<i>hGH</i> —High excess gain mode	PErF
Output (<i>out 1, out 2</i>)	<i>Lo</i> —Light Operate	<i>Lo</i> —Light Operate
Response Speed (<i>SPd</i>)	<i>25</i> —25 ms	<i>50</i> —50 ms
Shift the Zero Reference Location after a TEACH (<i>shft</i>)	<i>off</i> —0 = the front of the sensor	<i>off</i> —0 = the front of the sensor

Setting	2000 mm Model Factory Default	5000 mm Model Factory Default
TEACH Mode (<i>teach</i>)	<i>2-PT</i> —Two-point TEACH	<i>2-PT</i> —Two-point TEACH
Zero Reference Location (<i>zero</i>)	<i>near</i> —Measurement increases further from sensor	<i>near</i> —Measurement increases further from sensor
Hysteresis (<i>hys</i>)	<i>Auto</i> —Sensor controls value	<i>Auto</i> —Sensor controls value
Display Units (<i>unit</i>)	<i>cm</i> —Centimeters	<i>cm</i> —Centimeters
Output Polarity (<i>pol</i>)	<i>DEF</i> —Default: IO-Link on pin 4 and PNP on pin 2	<i>DEF</i> —Default: IO-Link on pin 4 and PNP on pin 2

3.3 Manual Adjustments



Manually adjust the sensor switch point using the  and  buttons.

1. From Run mode, press either  or  one time. The selected channel displays briefly, then the current switch point value flashes slowly.
2. Press  to move the switch point up or  to move the switch point down. After 1 second of inactivity, the new switch point value flashes rapidly, the new setting is accepted, and the sensor returns to Run mode.



Note: When FGS mode is selected (FGS indicator is on), manual adjustment moves both sides of the symmetrical threshold window simultaneously, expanding and collapsing the window size. Manual adjustment does not move the center point of the window.



Note: When dual mode is selected (DYN, FGS, and BGS indicators are on), after the TEACH process is completed, use the manual adjustment to adjust the sensitivity of the thresholds around the taught reference point. The taught reference point is a combination of the measured distance and returned signal intensity from the reference target. Manual adjustment does not move the taught reference point, but pressing  increases the sensitivity, and pressing  decreases the sensitivity. When re-positioning the sensor or changing the reference target, re-teach the sensor.

3.4 Remote Input

Remote input is available from the Channel 2 menu. Set **Out2** to **Set**.

Use the remote input to program the sensor remotely. The remote input provides limited programming options and is Active high. For Active high, connect the white input wire to ground (0 V dc), with a remote switch connected between the wire and ground. Pulse the remote input according to the diagram and the instructions provided in this manual.

The length of the individual programming pulses is equal to the value **T: 0.04 seconds ≤ T ≤ 0.8 seconds**.

Exit remote programming modes by setting the remote input high for longer than 2 seconds.

Figure 21. Remote Input Map

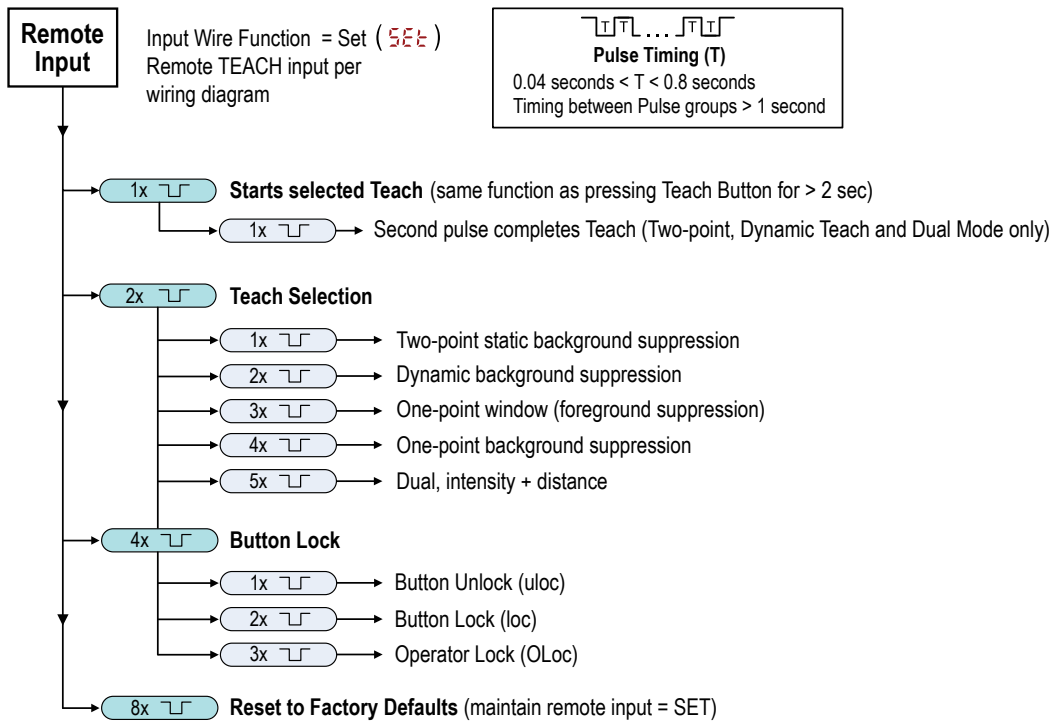



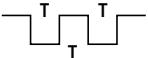

3.4.1 Select the TEACH Mode Using the Remote Input

1. Access the TEACH selection.

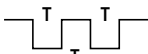
Action	Result
Double-pulse the remote input.	 teach displays.

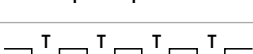
2. Select the desired TEACH mode.

Action		Result
Pulses	TEACH Mode	The selected TEACH method displays for a few seconds and the sensor returns to Run mode.
1 	Two-point static background suppression	
2 	Dynamic background suppression	
3 	One-point window (foreground suppression)	
4 	One-point background suppression	
5 	Dual (intensity + distance)	

3.4.2 Reset to Factory Defaults Using the Remote Input

Eight-pulse the remote input to apply the factory defaults and return to Run mode.



Note: The input wire function remains at remote teach input (**SEt**).

3.5 Locking and Unlocking the Sensor Buttons

Use the lock and unlock feature to prevent unauthorized or accidental programming changes. Three settings are available:

- **wLoc** —The sensor is unlocked and all settings can be modified (default).
- **Lac** — The sensor is locked and no changes can be made.
- **OLoc** —The switch point value can be changed by teaching or manual adjustment, but no sensor settings can be changed through the menu.



Note: When the sensor is in either **Lac** or **OLoc** mode, the active channel can be changed using **(+)(CH1/CH2)**.

When in **Lac** mode, **Lac** displays when the **(SELECT)(TEACH)** button is pressed. The switch point displays when **(+)(CH1/CH2)** or **(-)(MODE)** are pressed, but **Lac** displays if the buttons are pressed and held.

When in **OLoc** mode, **Lac** displays when **(-)(MODE)** is pressed and held. To access the manual adjust options, briefly press and release **(+)(CH1/CH2)** or **(-)(MODE)**. To enter TEACH mode, press the **(SELECT)(TEACH)** button and hold for longer than 2 seconds.

Button Instructions

To enter **Lac** mode, hold **+** and press **-** four times. To enter **OLoc** mode, hold **+** and press **-** seven times. Holding **+** and pressing **-** four times unlocks the sensor from either lock mode and the sensor displays **wLoc**.

Remote Input Instructions

1. Access the remote input.

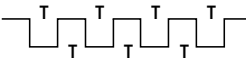
Action	Result
Four-pulse the remote input.	 The sensor is ready to have the button state defined and SEt displays.

2. Lock or unlock the sensor buttons.

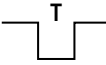
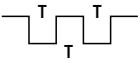
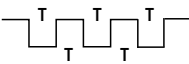
Action	Result
Single-pulse the remote input to unlock the sensor.	 wLoc displays and the sensor returns to Run mode.
Double-pulse the remote input to lock the sensor.	 Lac displays and the sensor returns to Run mode.
Triple-pulse the remote input to apply the operator lock to the sensor	 OLoc displays and the sensor returns to Run mode

3.6 TEACH Procedures

Use the following procedures to teach the sensor.

To cancel a TEACH procedure, press **TEACH** for longer than 2 seconds, or hold the remote input high for longer than 2 seconds. **EnE** momentarily displays when a TEACH procedure is canceled.

After any teach operation starts, the display temporarily flashes CH1 or CH2 to confirm which channel is currently selected.

3.6.1 Two-Point Static Background Suppression 2-PT

Two-point TEACH sets a single switch point. The sensor sets the switch point between two taught target distances, relative to the shifted origin location.

Figure 22. Two-Point Static Background Suppression (Light Operate shown)

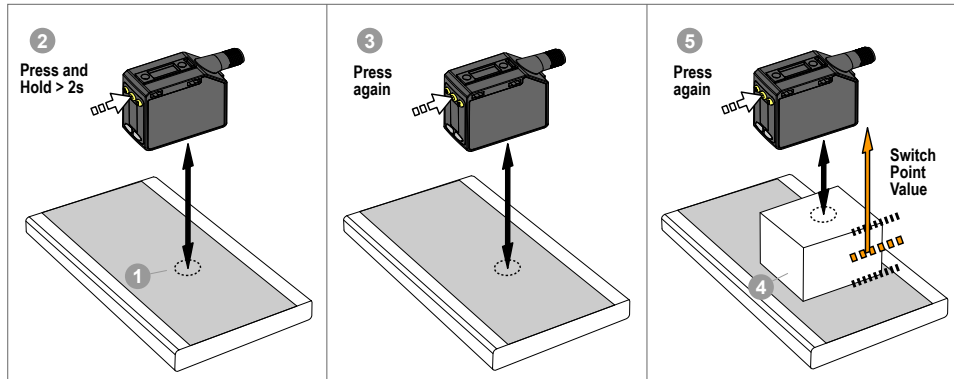

Note: The sensor must be set to tch = 2-PT to use the following instructions.



Note: To program the sensor using remote input, remote input must be enabled (out2 = SET).

1. Present the target.

Method	Action	Result
Push Button Remote Input	Present the first target. The sensor-to-target distance must be within the sensor's range.	The target's measurement value displays.

2. Start the TEACH mode.

Method	Action	Result
Push Button	Press and hold TEACH for longer than 2 seconds.	SET and 1st flash alternately on the display. The DYN, FGS, and BGS indicators flash.
Remote Input	No action required.	N/A

3. Teach the sensor.

Method	Action	Result
Push Button	Press TEACH to teach the target.	The sensor is taught the first target.
Remote Input	Single-pulse the remote input.	SET , 2nd , and the current distance measurement flash alternately on the display. The DYN, FGS, and BGS indicators flash.



4. Present the target.

Method	Action	Result
Push Button Remote Input	Present the second target. The sensor-to-target distance must be within the sensor's range.	SET , 2nd , and the distance measurement flash alternately on the display. The DYN, FGS, and BGS indicators flash.

5. Teach the sensor.

Method	Action	Result
Push Button	Press TEACH to teach the target.	The new switch point flashes rapidly and the sensor returns to Run mode.
Remote Input	Single-pulse the remote input. 	

Table 3: Expected TEACH Behavior for Two-Point Static Background Suppression
See [Performance Curves](#) on p. 35 for the minimum object separation.

Condition	TEACH Result	Display
Two valid distances that are greater than or equal to the horizontal minimum object separation	Sets a switch point between the two taught distances.	The switch point distance flashes on the display.
Two valid distances that are less than the horizontal minimum object separation	Sets a switch point in front of the furthest taught distance equal to the uniform reflectivity minimum object separation.	bcs and the switch point distance flash alternately on the display.
One valid distance with one invalid TEACH point	Sets a switch point between the one taught distance and the maximum range.	obut and the switch point distance flash alternately on the display.
Two invalid TEACH points	Sets a switch point for the currently selected channel at 197 cm.	Full and the switch point distance flash alternately on the display.

3.6.2 Dynamic Background Suppression **dyn**

Dynamic TEACH sets a single switch point during machine run conditions. Dynamic TEACH is recommended for applications where a machine or process may not be stopped for teaching. The sensor takes multiple samples and the switch point is set between the minimum and the maximum sampled distances.

Figure 23. Dynamic Background Suppression

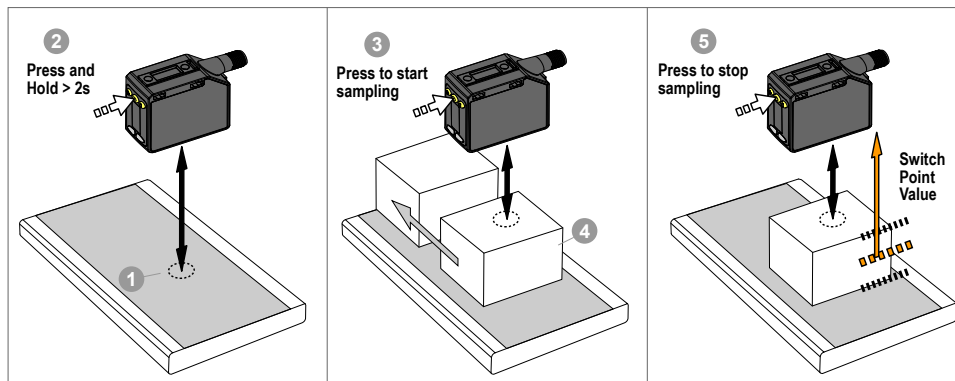

Note: The sensor must be set to **tch = dyn** to use the following instructions. The DYN indicator is amber to indicate Dynamic TEACH mode.



Note: To program the sensor using remote input, remote input must be enabled (**out2 = Set**).

1. Present the target.

Method	Action	Result
Push Button	Present the first target. The sensor-to-target distance must be within the sensor's range.	The target's measurement value displays.
Remote Input		

2. Start the TEACH mode.

Method	Action	Result
Push Button	Press and hold TEACH for longer than 2 seconds.	dyn and Stop flash alternately on the display. The DYN indicator flashes.
Remote Input	No action required.	N/A

3. Teach the sensor.

Method	Action	Result
Push Button	Press TEACH to teach the target.	The sensor begins sampling target distance information and dyn and Stop flash alternately on the display. The DYN indicator flashes.
Remote Input	Single-pulse the remote input. 	

4. Present the targets.

Method	Action	Result
Push Button	Present additional targets. The sensor-to-target distance must be within the sensor's range.	The sensor continues to sample target distance information and dyn and Stop flash alternately on the display. The DYN indicator flash.
Remote Input		

5. Teach the sensor.

Method	Action	Result
Push Button	Press TEACH to stop teaching the sensor.	The new switch point flashes rapidly and the sensor returns to Run mode.
Remote Input	Single-pulse the remote input. 	

Table 4: Expected TEACH Behavior for Dynamic Background Suppression
See [Performance Curves](#) on p. 35 for the minimum object separation.

Condition	TEACH Result	Display
Two valid distances that are greater than or equal to the horizontal minimum object separation	Sets a switch point between the two taught distances.	The switch point distance flashes on the display.
Two valid distances that are less than the horizontal minimum object separation	Sets a switch point in front of the furthest taught distance equal to the uniform reflectivity minimum object separation.	b05 and the switch point distance flash alternately on the display.
One valid distance with one invalid TEACH point	Sets a switch point between the one taught distance and the maximum range.	obut and the switch point distance flash alternately on the display.
Two invalid TEACH points	Sets a switch point for the currently selected channel at 120 cm.	b05 and the switch point distance flash alternately on the display.

3.6.3 One-Point Window (Foreground Suppression) **F05**

One-point window sets a window (two switch points) centered around the taught target distance. Loss of signal is treated as a detection in One-Point Window mode. The size of the taught window is the vertical minimum object separation. See [Performance Curves](#) on p. 35.



Manually adjust the window size from Run mode using  and .

Figure 24. One-Point Window (Foreground Suppression)



In order to reliably detect changes from the taught background, if multiple laser reflections are returning to the sensor, the output status is treated as though the target is outside of the taught window. The display alternates between `2-L` and the measured distance. Realign the laser to avoid light reflecting off of multiple targets if this extra level of verification is not desired.

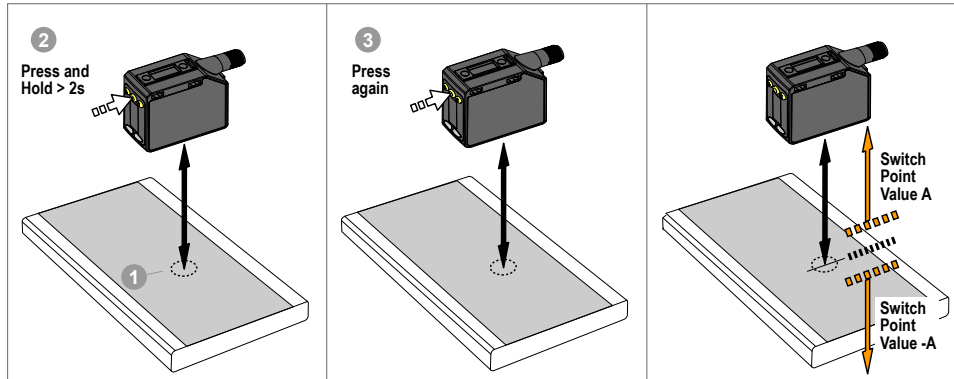

Note: The sensor must be set to `teach = FGS` to use the following instructions. The FGS indicator is amber to indicate One-Point Window (Foreground Suppression) mode.



Note: To program the sensor using remote input, remote input must be enabled (`out2 = Set`).

1. Present the target.

Method	Action	Result
Push Button	Present the target. The sensor-to-target distance must be within the sensor's range.	The target's measurement value displays.
Remote Input		

2. Start the TEACH mode.

Method	Action	Result
Push Button	Press and hold TEACH for longer than 2 seconds.	Light Operate <code>Set</code> and <code>on</code> flash alternately on the display. The FGS indicator flashes. Dark Operate <code>Set</code> and <code>off</code> flash alternately on the display. The FGS indicator flashes.
Remote Input	No action required.	N/A

3. Teach the sensor.

Method	Action	Result
Push Button	Press TEACH to teach the target.	The \pm window size flashes rapidly and the sensor returns to Run mode.
Remote Input	Single-pulse the remote input. 	

Table 5: Expected TEACH Behavior for One-Point Window (Foreground Suppression)
 See [Performance Curves](#) on p. 35 for the minimum object separation.

Condition	TEACH Result	Display
One valid TEACH point with both switch points in range (with offset, if applicable)	Sets a window (two switch points) centered around the taught distance. The ± window size is equal to the non-uniform reflectivity minimum object separation. The two switch points always stay within the specified sensing range.	The ± window size flashes on the display.
One invalid TEACH Point	Sets a window (two switch points) centered around 150 cm. The window size is ± 10 cm.	----- and the window center point distance flash alternately on the display.
One valid TEACH point with one switch point within range and one switch point out of range (with offset, if applicable)	Sets a window (two switch points) that is centered at the TEACH point (after offset, if applicable) with one switch point at the maximum range.	----- and the ± window size flash alternately on the display.
One valid TEACH point that, after the offset, results in a both switch points outside of the range	Sets a window (two switch points) centered around 150 cm. The window size is ± 10 cm.	ofst and the window center point distance flash alternately on the display.

3.6.4 One-Point Background Suppression b05

One-point background suppression sets a single switch point in front of the taught target distance. Objects beyond the taught switch point are ignored. The switch point is set in front of the taught target distance by the vertical minimum object separation. See [Performance Curves](#) on p. 35.

Figure 25. One-Point Background Suppression

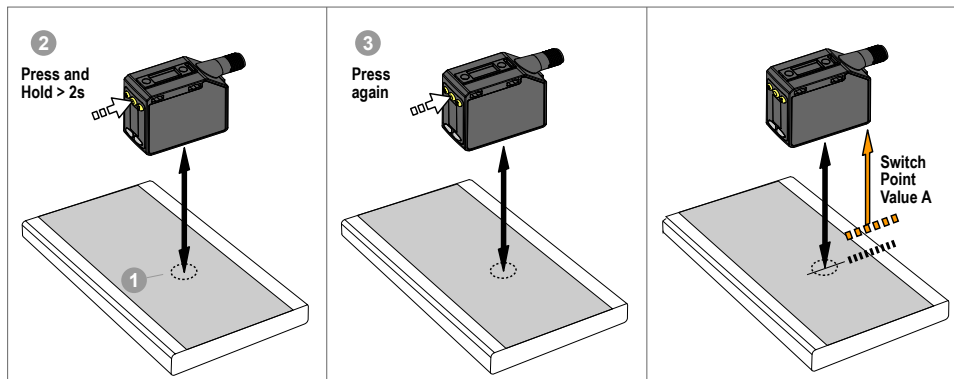

Note: The sensor must be set to tch = b05 to use the following instructions. The BGS indicator is amber to indicate Background Suppression mode.

Note: To program the sensor using remote input, remote input must be enabled (out2 = 5Et).

1. Present the target.

Method	Action	Result
Push Button	Present the target. The sensor-to-target distance must be within the sensor's range.	The target's measurement value displays.
Remote Input		

2. Start the TEACH mode.

Method	Action	Result
Push Button	Press and hold TEACH for longer than 2 seconds.	Light Operate <i>SET</i> and <i>OFF</i> flash alternately on the display. The BGS indicator flashes. Dark Operate <i>SET</i> and <i>ON</i> flash alternately on the display. The BGS indicator flashes.
Remote Input	No action required.	N/A

3. Teach the sensor.

Method	Action	Result
Push Button	Press TEACH to teach the target.	The new switch point flashes rapidly and the sensor returns to Run mode.
Remote Input	Single-pulse the remote input. 	

Table 6: Expected TEACH Behavior for One-Point Background Suppression
 See [Performance Curves](#) on p. 35 for the minimum object separation.

Condition	TEACH Result	Display
One valid TEACH point If an Offset is applied, the TEACH point is still valid	Sets a switch point in front of the taught distance equal to the non-uniform reflectivity minimum object separation.	The switch point distance flashes on the display.
One invalid TEACH point	Sets a switch point at 120 cm.	<i>BGS</i> and the switch point distance flash alternately on the display.
One valid TEACH point that, after offset, becomes invalid	Sets a switch point at 120 cm.	<i>OFFS</i> and the switch point distance flash alternately on the display.

3.6.5 Dual (Intensity + Distance) *dUAL*

Dual (intensity + distance) TEACH records the distance and amount of light received from the reference surface. The output switches when an object passing between the sensor and the reference surface changes the perceived distance or amount of returned light. For more information, see [Additional Information](#) on p. 38.



Note: To use the following instructions, set the sensor to *teCh* = *dUAL*. The DYN, FGS, and BGS indicators are amber.



Note: To program the sensor using remote input, remote input must be enabled (*out2* = *SET*).

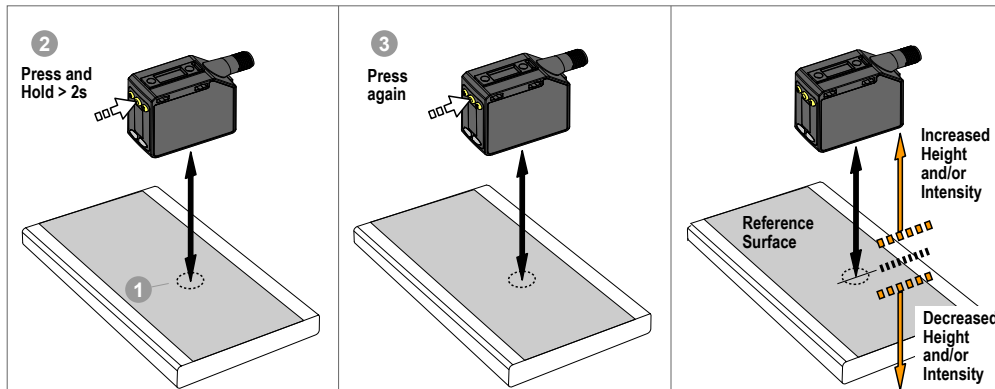

1. Present the target.

Method	Action	Result
Push Button Remote Input	Present the reference target.	The target's match percentage displays

2. Start the TEACH mode.

Method	Action	Result
Push Button	Press and hold the TEACH button for more than 2 seconds.	Light Operate: SET and ON flash on the display. The DYN, FGS, and BGS indicators flash. Dark Operate: SET and OFF flash on the display. The DYN, FGS, and BGS indicators flash.
Remote Input	No action required.	N/A

3. Teach the sensor.

Method	Action	Result
Push Button	Press the TEACH button.	The switching threshold flashes rapidly and the sensor returns to Run mode.
Remote Input	Single-pulse the remote input. 	

Table 7: Expected TEACH Behavior for Dual (Intensity + Distance) Mode

Condition	TEACH Result	Display
One valid reference surface is taught within sensing range	Sets a dual (intensity + distance) window centered around the taught reference surface. The ± window size is the previously used switching threshold, or 50% by default.	The switching threshold flashes on the display.
One reference surface is taught outside the sensing range	Sets a dual (intensity + distance) window centered around the taught reference surface that is outside the sensing range. The sensing conditions may not be as reliable.	OUT flashes on the display.
One invalid TEACH Point	No reference surface is taught, the output will change when any object is detected.	FULL flashes on the display.

3.7 Pulse Frequency Modulation (PFM) Output **PULS**

The Q5X can generate pulses whose frequency are proportional to the sensor's measured distance, thereby providing a method for representing an analog signal with only a discrete counter. The sensing range of the sensor is scaled from 100 to 600 Hz (100 Hz equals the near range limit of the sensor, 600 Hz equals the far sensing range limit). An output of 50 Hz represents a Loss of Signal (**LOS**) condition where there is no target or the target is out of the sensor's range.

3.8 Sync Master/Slave

Two Q5X sensors may be used together in a single sensing application. To eliminate crosstalk between the two sensors, configure one sensor to be the master and one to be the slave. In this mode, the sensors alternate taking measurements and the response speed doubles.



Important: The master sensor and the slave sensor must be programmed for the same Response Speed and Gain and Sensitivity settings. The master sensor and slave sensor must share a common power source.

1. Configure the first sensor as the master; navigate: **OUT2** > **ARST** .

2. Configure the second sensor as the slave; navigate: `out2 > SLAVE` .
3. Connect the white wires of the two sensors together.

4 IO-Link Interface

IO-Link is a point-to-point communication link between a master device and sensor. Use IO-Link to parameterize sensors and transmit process data automatically.

For the latest IO-Link protocol and specifications, see www.io-link.com.

Each IO-Link device has an IODD (IO Device Description) file that contains information about the manufacturer, article number, functionality etc. This information can be easily read and processed by the user. Each device can be unambiguously identified via the IODD as well as via an internal device ID. Download the Q5X's IO-Link IODD package (p/n 206833 for the 2000 mm models; 217156 for the 5000 mm models) from Banner Engineering's website at www.bannerengineering.com.

Banner has also developed Add On Instruction (AOI) files to simplify ease-of-use between the Q5X, multiple third-party vendors' IO-Link masters, and the Logix Designer software package for Rockwell Automation PLCs. Three types of AOI files for Rockwell Allen-Bradley PLCs are listed below. These files and more information can be found at www.bannerengineering.com.

Process Data AOIs—These files can be used alone, without the need for any other IO-Link AOIs. The job of a Process Data AOI is to intelligently parse out the Process Data word(s) in separate pieces of information. All that is required to make use of this AOI is an EtherNet/IP connection to the IO-Link Master and knowledge of where the Process Data registers are located for each port.

Parameter Data AOIs—These files require the use of an associated IO-Link Master AOI. The job of a Parameter Data AOI, when working in conjunction with the IO-Link Master AOI, is to provide quasi-realtime read/write access to all IO-Link parameter data in the sensor. Each Parameter Data AOI is specific to a given sensor or device.

IO-Link Master AOIs—These files require the use of one or more associated Parameter Data AOIs. The job of an IO-Link Master AOI is to translate the desired IO-Link read/write requests, made by the Parameter Data AOI, into the format a specific IO-Link Master requires. Each IO-Link Master AOI is customized for a given brand of IO-Link Master.

Add and configure the relevant Banner IO-Link Master AOI in your ladder logic program first; then add and configure Banner IO-Link Device AOIs as desired, linking them to the Master AOI as shown in the relevant AOI documentation.

5 Specifications

5.1 Specifications

Sensing Beam

Visible red Class 2 laser models, 650 nm

Supply Voltage (Vcc)

10 to 30 V DC (Class 2 supply) (10% max ripple within limits)

Supply Protection Circuitry

Protected against reverse polarity and transient overvoltages

Power and Current Consumption, exclusive of load

2000 mm model: < 1 W
5000 mm model: < 1.4 W

Sensing Range

2000 mm model: 95 mm to 2000 mm (3.74 in to 78.74 in)
5000 mm model: 50 mm to 5000 mm (2 in to 16.4 ft)

Output Configuration

Channel 1: IO-Link, Push/pull output, configurable PNP or NPN output
Channel 2: Multi-function remote input/output, configurable PNP or NPN, or pulse frequency modulated output

Output Rating

Current rating: 50 mA maximum

Black wire specifications per configuration		
IO-Link Push/Pull	Output High:	$\geq V_{supply} - 2.5 V$
	Output Low:	$\leq 2.5 V$
PNP	Output High:	$\geq V_{supply} - 2.5 V$
	Output Low:	$\leq 1V$ (loads ≤ 1 Meg Ω)
NPN	Output High:	$\geq V_{supply} - 2.5 V$ (loads ≤ 50 k Ω)
	Output Low:	$\leq 2.5 V$

White wire specifications per configuration		
PNP	Output High:	$\geq V_{supply} - 2.5 V$
	Output Low:	$\leq 2.5 V$ (loads ≤ 70 k Ω)
NPN	Output High:	$\geq V_{supply} - 2.5 V$ (loads ≤ 70 k Ω)
	Output Low:	$\leq 2.5 V$

Beam Spot Size

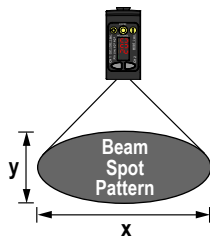

2000 mm Models		5000 mm Models	
Distance (mm)	Size (x × y) (mm)	Distance (mm)	Size (x × y) (mm)
100	2.6 × 1.5	100	6 × 4
1000	4.2 × 2.5	2500	11 × 7
2000	6 × 3.6	5000	15 × 11

Beam spot size is calculated as 1.6 times the D4 σ measured value

Boresighting

2000 mm model: ± 43 mm at 2000 mm
5000 mm model: ± 86 mm at 5000 mm

Response Speed

2000 mm model: User selectable 3, 5, 15, 25, or 50 ms
5000 mm model: User selectable 2, 5, 15, 50, or 250 ms

Delay at Power Up

< 2.5 s

Maximum Torque

Side mounting: 1 N·m (9 in·lbs)

Ambient Light Immunity

2000 mm model:
5000 lux at 1 m
2000 lux at 2 m
5000 mm model: 5000 lux

Connector

Integral 4-pin M12 male quick disconnect

Construction

Housing: ABS
Lens cover: PMMA acrylic
Lightpipe and display window: polycarbonate

Temperature Effect (Typical) for 2000 mm Models

< 0.5 mm/°C at < 500 mm
< 1.0 mm/°C at < 1000 mm
< 2.0 mm/°C at < 2000 mm

Temperature Effect (Typical) for 5000 mm Models

< 0.5mm/°C for up to 3000 mm
< 0.75mm/°C for up to 5000 mm

Discrete Output Distance Repeatability

Distance (mm)	Repeatability (2000 mm Models)
95 to 300	± 0.5 mm
300 to 1000	$\pm 0.25\%$
1000 to 2000	$\pm 0.5\%$

See the charts for the Repeatability of the 5000 mm models.

Remote Input

Allowable Input Voltage Range: 0 to Vsupply
Active High (internal weak pull-down): High state > (Vsupply – 2.25 V) at 2 mA maximum
Active Low (internal weak pull-up): Low state < 2.25 V at 2 mA maximum

IO-Link Interface

IO Link Revision V1.1
Smart Sensor Profile: Yes
Baud Rate: 38400 bps
Process Data In Length: 32 bits
Process Data Out Length: 8 bits
Minimum Cycle Time: 3.6 ms
IODD files: Provides all programming options of the display, plus additional functionality.

Application Note

For optimum performance, allow 10 minutes for the sensor to warm up for the 2000 mm models and 20 minutes for the 5000 mm models.

Environmental Rating

IEC IP67 per IEC60529

Vibration

MIL-STD-202G, Method 201A (Vibration: 10 Hz to 55 Hz, 0.06 inch (1.52 mm) double amplitude, 2 hours each along X, Y and Z axes), with device operating

Required Overcurrent Protection



WARNING: Electrical connections must be made by qualified personnel in accordance with local and national electrical codes and regulations.

Overcurrent protection is required to be provided by end product application per the supplied table. Overcurrent protection may be provided with external fusing or via Current Limiting, Class 2 Power Supply. Supply wiring leads < 24 AWG shall not be spliced. For additional product support, go to www.bannerengineering.com.

Supply Wiring (AWG)	Required Overcurrent Protection (Amps)
20	5.0
22	3.0
24	2.0
26	1.0
28	0.8
30	0.5

Shock

MIL-STD-202G, Method 213B, Condition I (100G 6x along X, Y, and Z axes, 18 shocks), with device operating

Operating Conditions

-10 °C to +50 °C (+14 °F to +122 °F)
35% to 95% relative humidity

Storage Temperature

-25 °C to +70 °C (-13 °F to +158 °F)

Certifications



Class 2 power
UL Environmental Rating: Type 1



Excess Gain for the 2000 mm Model

Response Speed (ms)	High Excess Gain (Standard Excess Gain) Using a 90% White Card ²			
	at 100 mm	at 500 mm	at 1000 mm	at 2000 mm
3	125	50	15	4
5	125	50	15	4
15	575 (175)	250 (75)	70 (25)	15 (6)
25	1000 (650)	450 (250)	125 (70)	30 (15)
50	2000 (1000)	900 (450)	250 (125)	60 (30)

Excess Gain for the 5000 mm Model ³

Gain Modes	Excess Gain Using a 90% White Card			
	at 50 mm	at 500 mm	at 2000 mm	at 5000 mm
Performance	80	600	245	40
Black	250	1800	750	135
Shiny	25	200	75	13

² Standard excess gain available in 15, 25, and 50 ms response speeds; standard excess gain provides increase noise immunity.

³ Excess gain is consistent for 15, 50, and 250 ms response speeds. Excess gain is approximately 10% lower in 2 ms and 5 ms response speed modes.

5.2 Dimensions

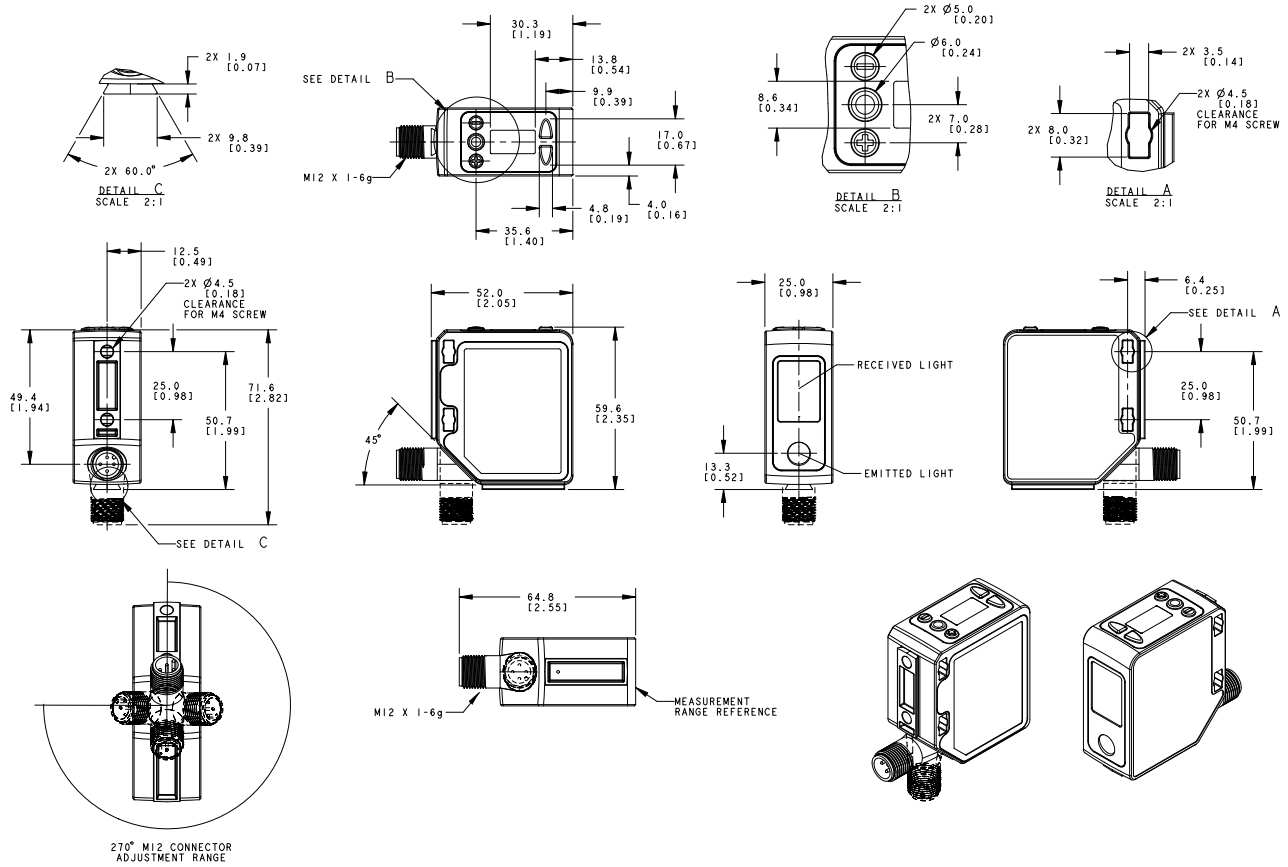

All measurements are listed in millimeters [inches], unless noted otherwise.

5.3 Performance Curves

5.3 2000 mm Models

Figure 26. Minimum Object Separation Distance (90% to 6% reflectance) for the 2000 mm Models

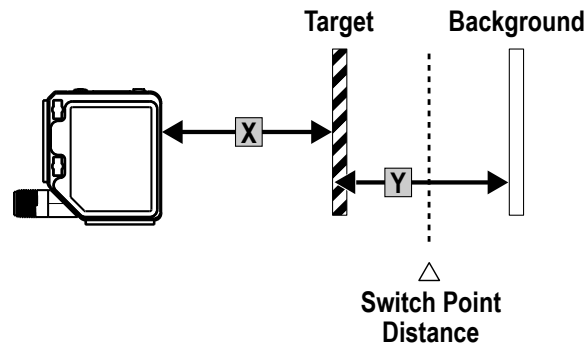
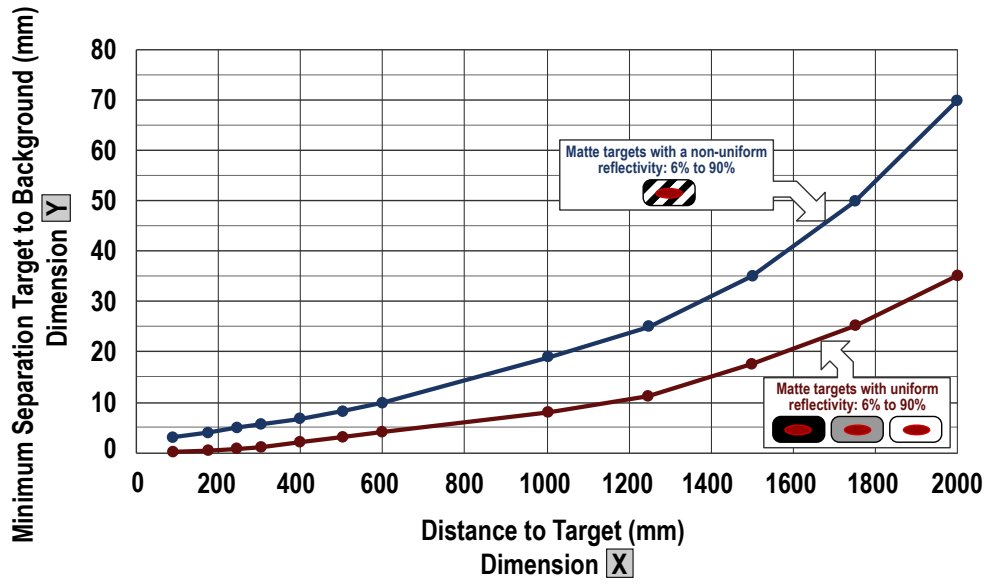

Figure 27. Performance for the 2000 mm Models



5.3 5000 mm Models

Minimum Object Separation ⁴	Repeatability
--	---------------

Figure 28. Minimum Object Separation for 250 ms Response Time

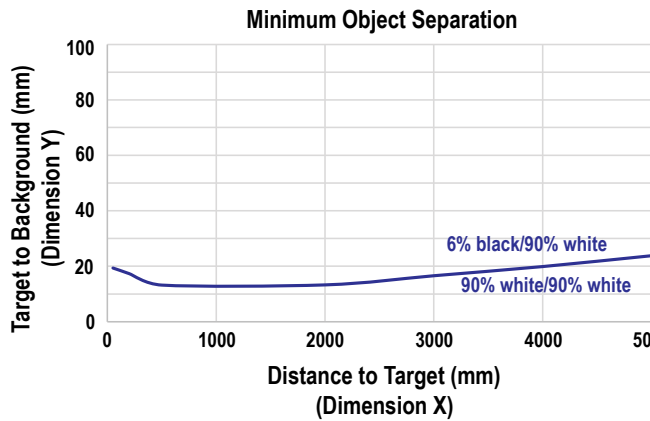
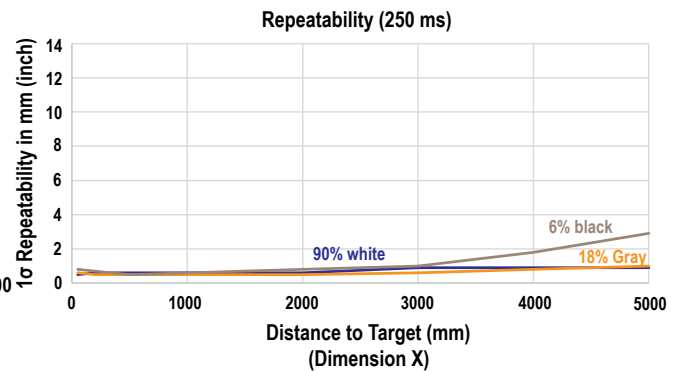

Figure 29. Repeatability for 250 ms Response Time



⁴ The Repeatability and Minimum Object Separation for 2 ms mode is approximately twice that of 5 ms mode.

Minimum Object Separation⁴

Repeatability

Figure 30. Minimum Object Separation for 50 ms Response Time

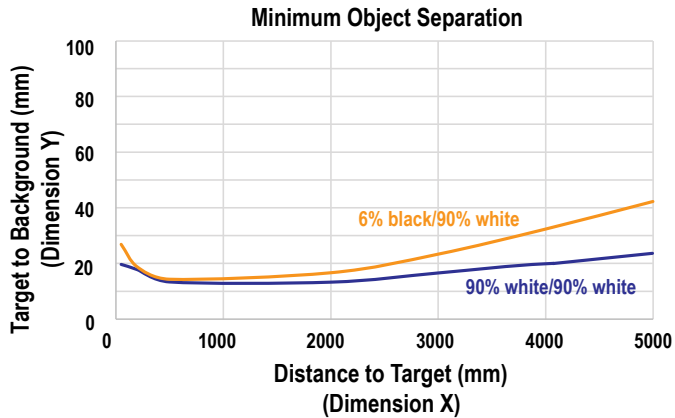

Figure 31. Repeatability for 50 ms Response Time

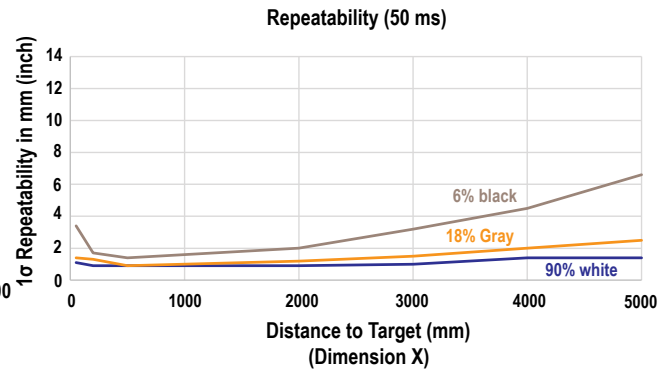

Figure 32. Minimum Object Separation for 15 ms Response Time

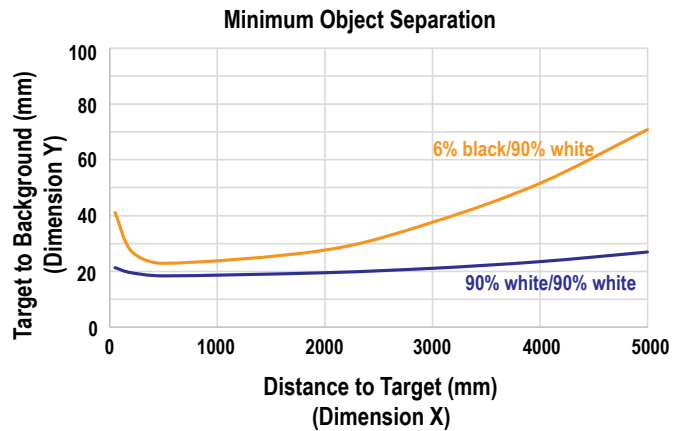

Figure 33. Repeatability for 15 ms Response Time

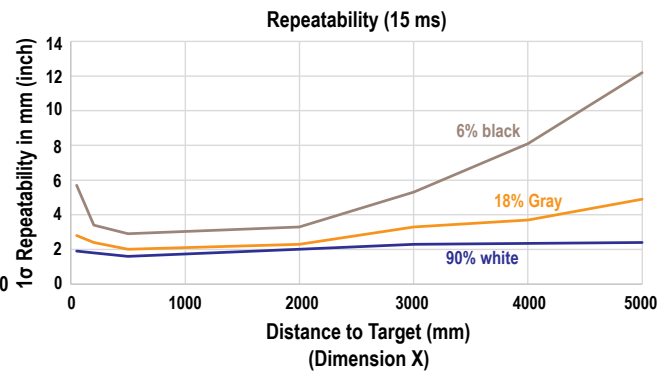

Figure 34. Minimum Object Separation for 5 ms Response Time

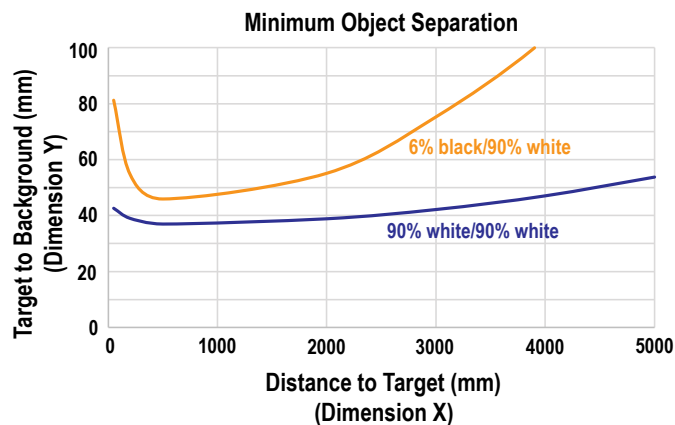
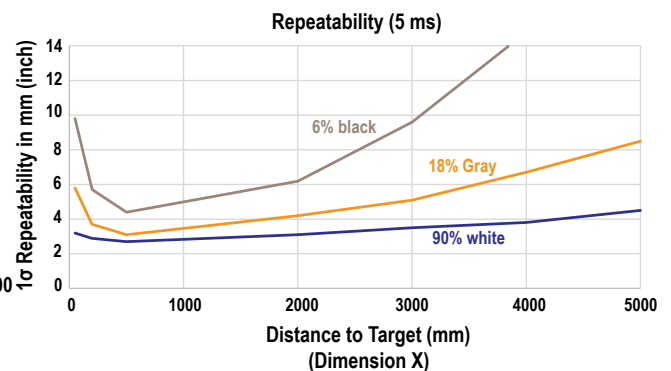

Figure 35. Repeatability for 5 ms Response Time



⁴ The Repeatability and Minimum Object Separation for 2 ms mode is approximately twice that of 5 ms mode.

6 Additional Information

6.1 Dual (Intensity + Distance) Mode

In background suppression (DYN, 1-pt, 2-pt) and foreground suppression (FGS) TEACH modes, the Q5X sensor compares changes in the measured distance between the sensor and target to control the output state. Dual TEACH mode, dual intensity + distance window, expands the applications the Q5X can solve by combining distance-based detection with light intensity thresholds. In dual TEACH mode, the user teaches the Q5X a fixed reference surface, and the sensor compares intensity and distance readings against the reference surface it was taught. After teaching the reference target, the displayed value is calibrated to 100P, or a 100% match. When an object enters the sensor's field of view, the degree of consistency with the reference surface becomes lower and causes a change in sensor output.

In dual mode, you can detect when the target is present at the right distance and when it returns the right amount of light. This is useful in error-proofing applications where you need to know not only that the part is present (distance), but also that it is the correct part (intensity).

In dual mode, the Q5X requires a reference surface (far left). Once taught, the distance and intensity of the reference surface are recorded and used as a baseline. A user-adjustable switching threshold is set, and changes in distance and/or intensity outside the switching threshold creates a sensor output change. The example uses a 90% (90P) match condition with a 10% change in intensity and/or distance from the reference surface required to change the output state. The default-switching threshold is a 50% match to the reference condition (50P); this sets the threshold 50% from the distance and intensity of the reference surface. A transparent object can be detected either by a change in intensity, distance, or by a double peak reflection (far right).

Figure 36. Dual Mode Example

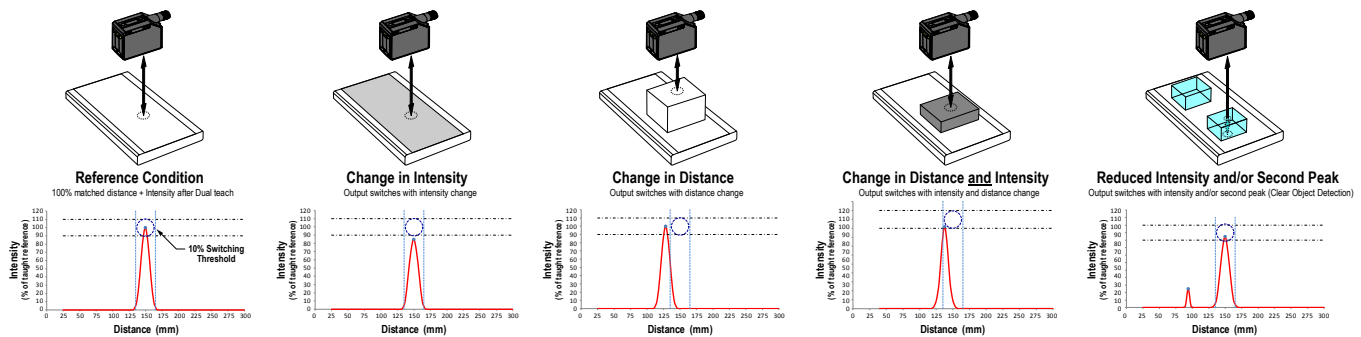

The Q5X sensor can be taught non-ideal reference surfaces, such as surfaces outside of the sensor's range, very dark surfaces, or even empty space. These situations may enable applications requiring a long range detection but are subject to typical diffuse mode detection challenges.

6.2 Dual Mode Reference Surface Considerations

Optimize reliable detection by applying these principals when selecting your reference surface, positioning your sensor relative to the reference surface, and presenting your target. The robust detection capabilities of the Q5X allows successful detection even under non-ideal conditions in many cases. Typical reference surfaces are metal machine frames, conveyor side rails, or mounted plastic targets. Contact Banner Engineering if you require assistance setting up a stable reference surface in your application.

1. Select a reference surface with these characteristics where possible:
 - Matte or diffuse surface finish
 - Fixed surface with no vibration
 - Dry surface with no build-up of oil, water, or dust
2. Position the reference surface between 200 mm (20 cm) and the maximum sensing range.
3. Position the target to be detected as close to the sensor as possible, and as far away from the reference surface as possible.
4. Angle the sensing beam relative to the target and relative to the reference surface 10 degrees or more.

6.3 Dual Mode Considerations for Clear and Transparent Object Detection

The Q5X is able to detect the very small changes caused by transparent and clear objects. A transparent object can be detected either by a change in intensity, distance, or by a double-peak reflection.

The Q5X sensor can be taught non-ideal reference surfaces, such as surfaces outside of the sensor range or very dark surfaces. Teaching non-ideal reference surfaces may enable applications other than transparent or clear object detection, but best results for transparent or clear object detection require a stable reference surface.

The display shows the match percentage to the taught reference point. The user adjustable switch point defines the sensitivity and the output switches when the match percentage to the reference point crosses the switch point. Your specific application may require fine tuning of the switch point, but these values are the recommended starting values:

Switch point (%)	Typical Applications
50 (default)	Default, recommended for PET bottles and Trays
88	Recommended for thin films
50	Recommended for tinted brown, tinted green, or water-filled containers

Figure 37. Example mounting considerations

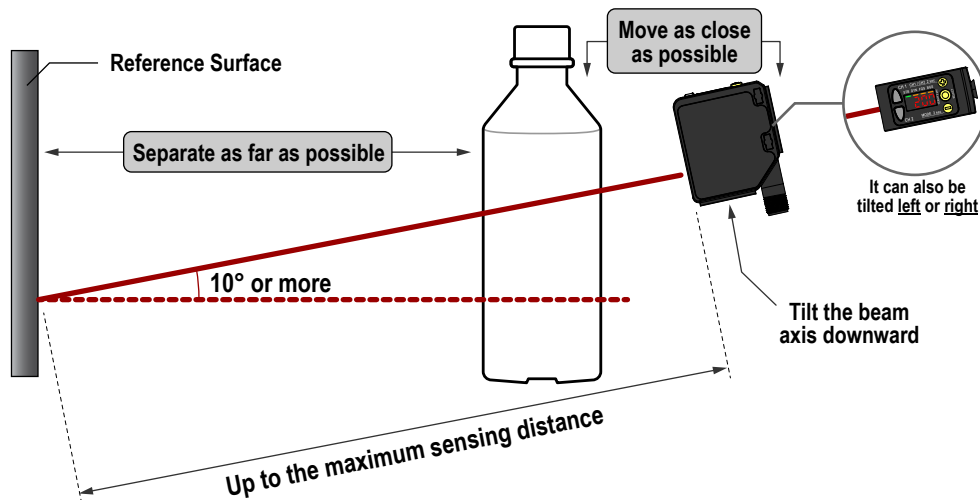
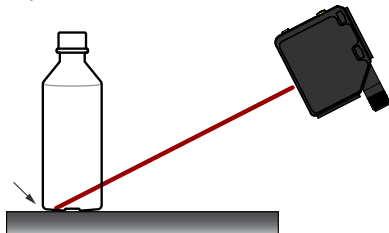

Figure 38. Common problems and solutions for detecting clear objects

PROBLEM:

The object is close to the reference surface



SOLUTION:

Move the target closer to the sensor

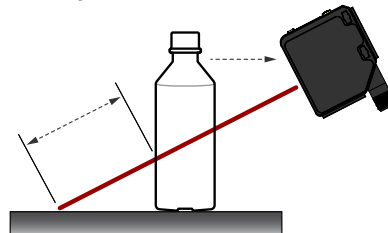

PROBLEM:

The sensor is far from the object

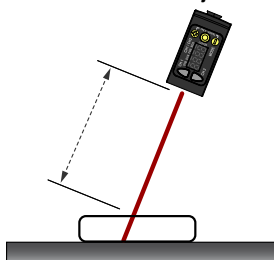

SOLUTION:

Move the sensor closer to the target

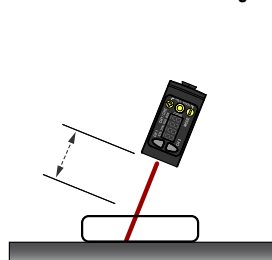

6.4 Abbreviations

The following table describes the abbreviations used on the sensor display and in this manual.

Abbreviation	Description
----	No valid signal in range
9999	The sensor has not been taught
1Shot	One-shot
1st	First
2nd	Second
2-Pt	Two-point TEACH (static background suppression)
Auto	Automatic
BO5	One-point background suppression
btn	Button
CanCL	Cancel
comp	Complementary output
disP	Display read
DLAY	Delay
DLAY1, DLAY2	Output timing delay (Channel 1, Channel 2)
do	Dark operate
dt1, dt2	Delay timer (Channel 1, Channel 2)
dual	Dual mode
dyn	Dynamic background suppression
End	End—exit the sensor menu
FAR	Far zero reference location—the maximum range is 0 and the measurement increase as the target moves closer to the sensor
FG5	One-point window (foreground suppression)
FULL	Full range
GA in	Excess gain
high	High excess gain mode
HS	High speed tracking
HYS	Hysteresis
Lo	Light operate
L on	Laser on
Loc	Lock/locked

Abbreviation	Description
LoFF	Laser off
MASt	Master
nEAR	Near zero reference location—the front of the sensor is 0 and the measurement increase as the target moves further away from the sensor
obJt	Object
oFd1, oFd2	Off delay timer (Channel 1, Channel 2)
oFF	Off
oFS1, oFS2	Offset (Channel 1, Channel 2)
oFSt	An applied offset resulted in an invalid switch point
oN	On
oNd1, oNd2	On delay timer (Channel 1, Channel 2)
oUt1, oUt2	Output (Channel 1, Channel 2)
Pol	Output type polarity
PULS	Pulse frequency modulation
rSEt	Reset to factory defaults
SAVE	Save
SEt	Set or Input wire = remote teach function
SHFt	Shift the Zero Reference Location after a TEACH
SLVE	Slave
SPd	Response speed
Std	Standard excess gain mode
StAr	Start
StoP	Stop
tch1, tch2	TEACH process selection (Channel 1, Channel 2)
totL	Totalizer
tot1, tot2	Total counts
uLoc	Unlock/unlocked
unit	Unit
www	Saturated signal (too much light)
wNd1, wNd2	Window size (Channel 1, Channel 2)
YES	Yes
ZEro	Zero—select the zero reference location

7 Accessories

7.1 Cordsets

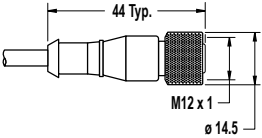
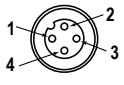
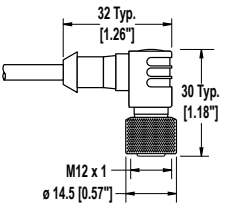
4-Pin Threaded M12 Cordsets—Single Ended				
Model	Length	Style	Dimensions	Pinout (Female)
MQDC-406	2 m (6.56 ft)	Straight		 <p>1 = Brown 2 = White 3 = Blue 4 = Black</p>
MQDC-415	5 m (16.4 ft)			
MQDC-430	9 m (29.5 ft)			
MQDC-450	15 m (49.2 ft)			
MQDC-406RA	2 m (6.56 ft)	Right-Angle		
MQDC-415RA	5 m (16.4 ft)			
MQDC-430RA	9 m (29.5 ft)			
MQDC-450RA	15 m (49.2 ft)			

7.2 Brackets

All measurements are listed in millimeters, unless noted otherwise.

SMBQ5X..

- Swivel bracket with tilt and pan movement for precision adjustment
- Easy sensor mounting to extruded rail T-slots
- Metric and inch size bolts available
- Side mounting of some sensors with the 3 mm screws included with the sensor

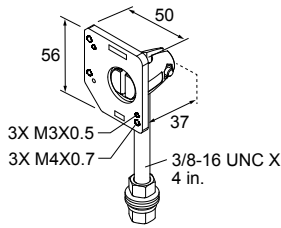

B = 7 × M3 × 0.5

Model	Bolt Thread (A)
SMBQ5XFAM	3/8 - 16 × 2¼ in
SMBQ5XFAM10	M10 - 1.5 × 50
SMBQ5XFAM12	n/a; no bolt included. Mounts directly to 12 mm (½ in) rods

SMBAMSQ5XIPRA

- Enclosed bracket
- 13-ga. Stainless steel with borosilicate glass window
- Right angle mount plate

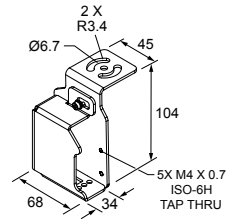

SMBAMSQ5XIPP

- Enclosed bracket
- 13-ga stainless steel with a borosilicate glass window
- Flat mount plate

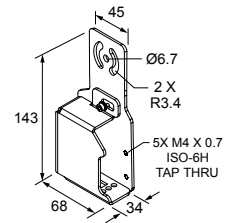

SMBQ5XDT

- Clamp bracket mounts to sensor dovetail
- Translation adjustment for sensor alignment
- Aluminum clamp - 6.5mm maximum plate thickness

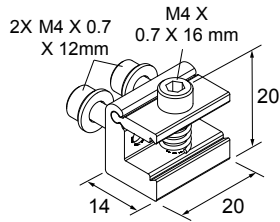

SMBAMSQ5XP

- Flat SMBAMS series bracket
- Articulation slots for 30 deg rotation
- 13-ga. 304 stainless steel

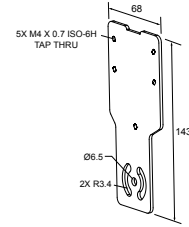

SMBAMSQ5XRA

- Right-angle SMBAMS series bracket
- Articulation slots for 30 deg rotation
- 13-ga. 304 stainless steel

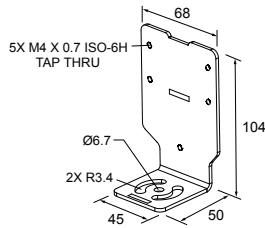

SMBQ5XM4F

- Fixing plates for mounting to back of sensor
- Stainless steel plates
- Customer supplied mounting plate thickness minimum 2 mm maximum 4 mm with screws included in kit

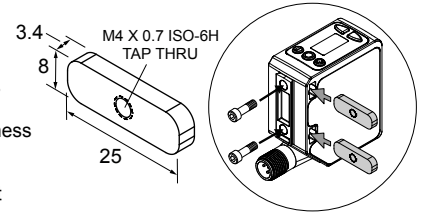

7.3 Reference Targets

All measurements are listed in millimeters, unless noted otherwise.

BRT-Q4X-60X18

- Reference target for clear object detection or dual mode applications
- FDA grade acetal material

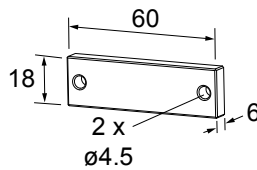

BRT-Q4X-60X50

- Reference target for clear object detection or dual mode applications
- FDA grade acetal material

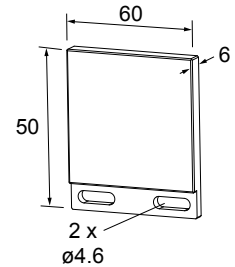

7.4 RSD1 Remote Display

Use the optional RSD1 for remote monitoring and configuring compatible devices.

Refer to the RSD1 instruction manual (p/n 199621) or quick start guide (p/n 199622) for more information. See [Accessories](#) on p. 42 for the required cordsets.

RSD1 Remote Display				
Model	Output A and B	Dimensions	Male	Wiring
RSD1QP	Configurable			1 = Brown 2 = White 3 = Blue 4 = Black 5 = Gray

8 Product Support and Maintenance

8.1 Troubleshooting

Table 8: Error Codes

Error Code	Description	Resolution
----	No valid signal in range	Reposition the sensor or the target
UUUU	The signal is saturated (too much light)	Reposition the sensor or the target to increase the detection distance, or increase the angle of incidence between the sensor and the target
ErrE	EEPROM fault	Contact Banner Engineering to resolve
ErrL	Laser fault	Contact Banner Engineering to resolve
ErrC	Output short-circuited	Check the wiring for an electrical short circuit and to ensure that the wiring is correct
ErrS	System fault	Contact Banner Engineering to resolve

8.2 Contact Us

Banner Engineering Corp. headquarters is located at:

9714 Tenth Avenue North
 Minneapolis, MN 55441, USA
 Phone: + 1 888 373 6767

For worldwide locations and local representatives, visit www.bannerengineering.com.

8.3 Banner Engineering Corp. Limited Warranty

Banner Engineering Corp. warrants its products to be free from defects in material and workmanship for one year following the date of shipment. Banner Engineering Corp. will repair or replace, free of charge, any product of its manufacture which, at the time it is returned to the factory, is found to have been defective during the warranty period. This warranty does not cover damage or liability for misuse, abuse, or the improper application or installation of the Banner product.

THIS LIMITED WARRANTY IS EXCLUSIVE AND IN LIEU OF ALL OTHER WARRANTIES WHETHER EXPRESS OR IMPLIED (INCLUDING, WITHOUT LIMITATION, ANY WARRANTY OF MERCHANTABILITY OR FITNESS FOR A PARTICULAR PURPOSE), AND WHETHER ARISING UNDER COURSE OF PERFORMANCE, COURSE OF DEALING OR TRADE USAGE.

This Warranty is exclusive and limited to repair or, at the discretion of Banner Engineering Corp., replacement. **IN NO EVENT SHALL BANNER ENGINEERING CORP. BE LIABLE TO BUYER OR ANY OTHER PERSON OR ENTITY FOR ANY EXTRA COSTS, EXPENSES, LOSSES, LOSS OF PROFITS, OR ANY INCIDENTAL, CONSEQUENTIAL OR SPECIAL DAMAGES RESULTING FROM ANY PRODUCT DEFECT OR FROM THE USE OR INABILITY TO USE THE PRODUCT, WHETHER ARISING IN CONTRACT OR WARRANTY, STATUTE, TORT, STRICT LIABILITY, NEGLIGENCE, OR OTHERWISE.**

Banner Engineering Corp. reserves the right to change, modify or improve the design of the product without assuming any obligations or liabilities relating to any product previously manufactured by Banner Engineering Corp. Any misuse, abuse, or improper application or installation of this product or use of the product for personal protection applications when the product is identified as not intended for such purposes will void the product warranty. Any modifications to this product without prior express approval by Banner Engineering Corp will void the product warranties. All specifications published in this document are subject to change; Banner reserves the right to modify product specifications or update documentation at any time. Specifications and product information in English supersede that which is provided in any other language. For the most recent version of any documentation, refer to: www.bannerengineering.com.

For patent information, see www.bannerengineering.com/patents.

Index

I

IO-Link 32