

# H4 Tech-Note

---

## Wireless Handheld 5" TFT ARM Cortex-A8 - 600 MHz

- 5" TFT color display
- 480x272 pixel resolution, 64K colors
- Resistive touchscreen
- USB Host port
- Emergency stop button
- 3-positions enabling switch
- 2 potentiometers
- 1 optional handwheel
- 19 user-programmable selection keys



## Highlights

The H4 Wireless Handheld HMI is a compact and lightweight device with an ergonomic design. Wireless connection with certification for safety devices makes this product the ideal solution for industrial applications. Integrated devices (Keyboard, potentiometers, handwheel) can be fully programmed assuring a quick use with your automation project. H4 is fully programmable with JMobile.

The H4 Wireless handheld brings the power and flexibility of JMobile HMI to the factory floor. Wireless connection with certified functional safety avoids the safety concerns related to cable in industrial environments.

The H4 handheld has been designed to run the JMobile software. It includes a JMobile runtime. Full compatibility with JMobile V2.0 or higher.

- Supports JMobile Ethernet protocols
- Requires a Wi-Fi access point for Ethernet communication (not part of the delivery package)
- Hanging magnets

# H4 - Technical Data



System Resources	
Display - Colors	TFT LED - 64K
Resolution	480x272
Brightness	300 Cd/m <sup>2</sup> typ.
Dimming	to 0%
Touchscreen	Resistive
CPU	ARM Cortex-A8 - 600 MHz
Operating System	Microsoft Windows CE 6.0
Flash	128 MB
RAM	256 MB
Real Time Clock, RTC Back-up	Yes
Handwheel	Yes
Potentiometer	2
Selector Switch	16 positions
Emergency stop	Yes
Enabling Switch	3 positions
Interface	
Ethernet	Wi-Fi 802.11
USB port	1 Host V2.0
Bluetooth	Reserved for safety functions
Ratings	
Power supply (charging station)	24 Vdc (18 to 30 Vdc)
Current Consumption	0.25 A at 24 Vdc (max.)
Input Protection	Automatic
Battery	Rechargeable Lithium battery, not user-replaceable
Environment Conditions	
Operating Temp	+5 to +45°C
Storage Temp	-20 to +70°C
Operating / Storage Humidity	5-85% RH, non condensing
Protection Class	IP64
Dimensions and Weights	
Faceplate LxH	220x144 mm
Depth D+T	63 mm
Weight	Approx 0.8 Kg
Approvals	
CE	Emission EN 61000-6-4 Immunity EN 61000-6-2 for installation in industrial environments
Safety	2006/42/EC, EN ISO 13849-1:2008, EN 62061 :2005/A1:2013, EN 60204-1:2006/A1:2009
Safety functions	Emergency Stop cat 3, PL d / SIL 2 Enabling cat 3, PL d / SIL 2 Selector, cat 1, PL c / SIL 1
UL	cULus: UL508

- 1 Token receptacle
- 2 Stop pushbottom
- 3 Enabling device
- 4 Selector
- 5 Potentiometers
- 6 Handwheel
- 7 Membrane Keypad
- 8 Touchscreen pen
- 9 Mounting magnets
- 10 Status LED's
- 11 Battery Charging Contacts

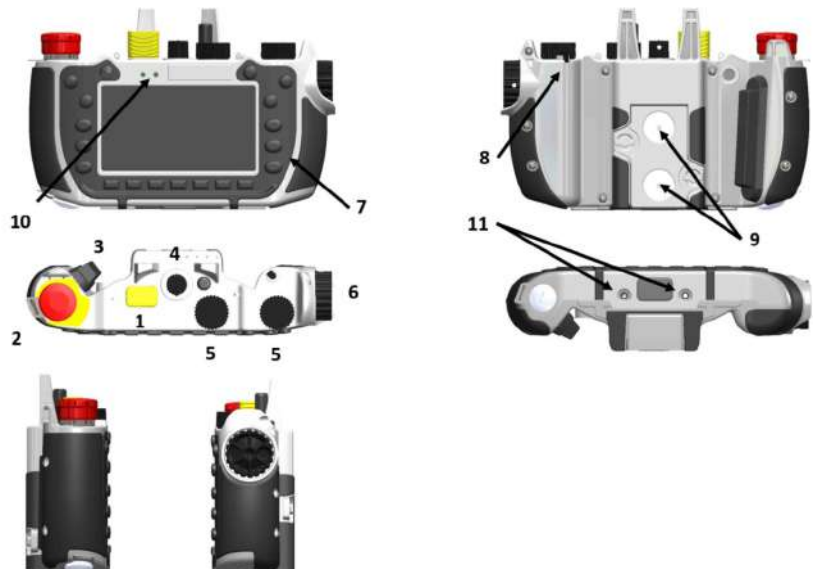

## Ordering Information

Part Number	Description
10100080YE-0000	HMI H4 ON3 WIRELESS JM
10500080YA-0000	ANTENNA + COUPLING TOKEN
10200080YA-0000	RECHARGING STATION H4
10200080YA-0001	CIS H4