

eTOP515 Tech-Note

15" TFT

ARM Cortex-A8 - 1 GHz

- 5 Year Warranty
- Innovative mechanical design and all-metal enclosure
- High-performance touchscreen HMI's
- Brilliant displays with LED technology all in full color
- Gateway function, remote installation of application and remote assistance
- Ethernet, USB, serial ports and MPI integrated
- Optional plug-in modules for fieldbus systems and networks
- Support SD Card
- Coating on all Electronic Boards
- Optional IEC 61131-3 integrated PLC (CODESYS V2 or V3)
- Front available in three colors (White/Black/Silver)
- Special versions for special applications



Highlights

The eTOP515 features a **bright 15" TFT display** with a fully dimmable LED backlight.

Hardware and software choices made by EXOR enhance its communication capability and make it the ideal choice for your applications.

The JMobile software offers full vector graphic capabilities and a **complete set of connectivity options**.

The eTOP Series 500 combine state-of-the-art features and top performance with an **outstanding design**.

The eTOP Series 500 come with a choice of certifications and approvals that make them the solution of **choice for all requirements**.

eTOP515 - Technical Data

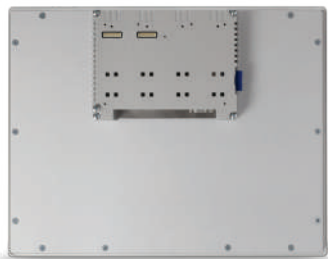

| | |
|--------------------------------------|--|
| System Resources | |
| Display - Colors | 15" TFT LED - 64K |
| Resolution | 1024x768, XGA |
| Brightness | 300 Cd/m ² typ. |
| Dimming | to 0% |
| Touchscreen | Resistive |
| CPU | ARM Cortex-A8 - 1 GHz |
| Operating System | Microsoft Windows CE 6.0 |
| Flash | 256 MB |
| RAM | 256 MB DDR |
| Real Time Clock, RTC Back-up, Buzzer | Yes, Yes, Yes |
| Interface | |
| Ethernet port | 2 (port 0 - 10/100, port 1 - 10/100) with integrated Switch |
| USB port | 2 (port 1 - Host V2.0, port 2 - Host V2.0/1.1) |
| Serial port | 1 (RS-232, RS-485, RS-422, MPI software configurable) |
| SD card | Yes |
| Expansion | 2 slot for plug in modules |
| Ratings | |
| Power supply | 24 Vdc (10 to 32 Vdc) |
| Current Consumption | 1.25 A at 24 Vdc (max.) |
| Input Protection | Automatic |
| Battery | Rechargeable Lithium battery, not user-replaceable |
| Environment Conditions | |
| Operating Temp | 0 to +50 °C |
| Storage Temp | -20 to +70 °C |
| Operating / Storage Humidity | 5-85% RH, non condensing |
| Protection Class | IP66 (front), IP20 (rear) Type: 12, 4X |
| Dimensions and Weights | |
| Faceplate LxH | 392x307 mm (15.43x12.08") |
| Cutout AxB | 381x296 mm (15x11.65") |
| Depth D+T | 60+4 mm (2.36+0.16") |
| Weight | Approx 3.5 Kg |
| Approvals | |
| CE | Emission EN 61000-6-4 Immunity EN 61000-6-2 for installation in industrial environments |
| UL | cULus: UL508 |
| UL | cULus: Class I Div. 2 |
| DNV-GL | Yes |
| RCM | Yes |

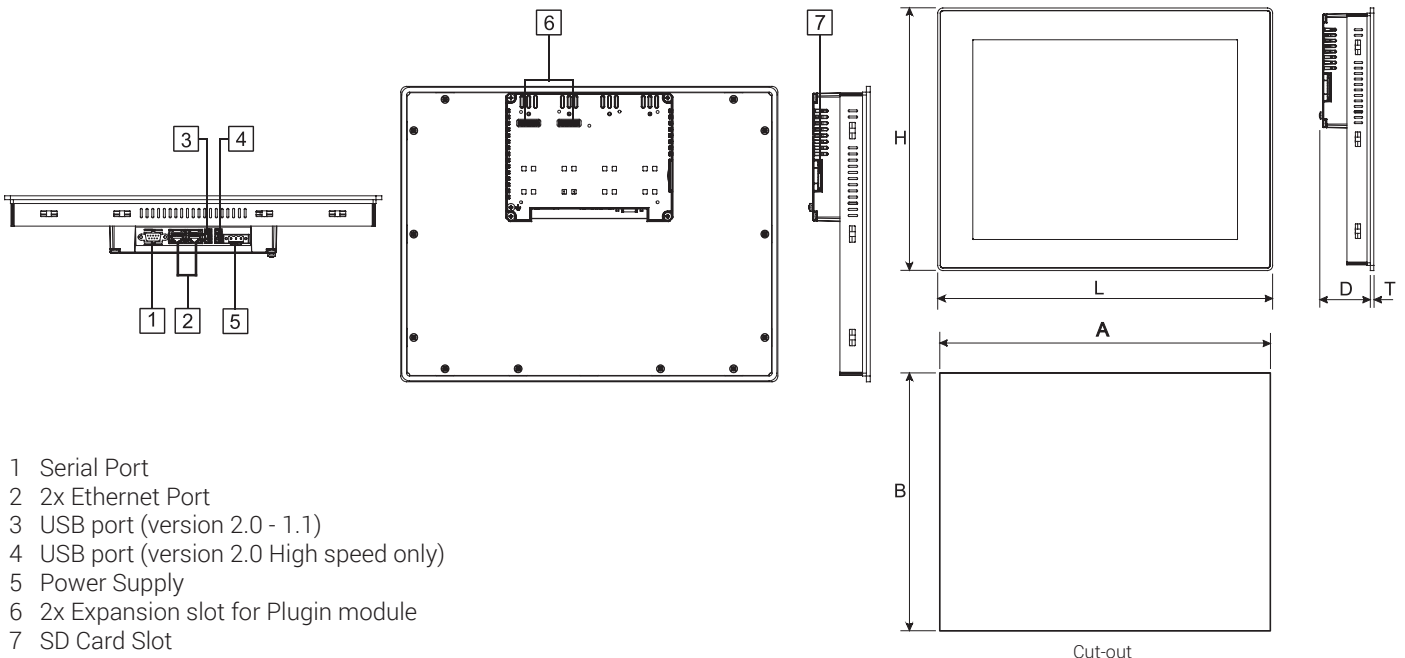

Ordering Information

| Model | Part Number | Description |
|----------------|--------------|--|
| eTOP515-White | +ETOP515U1P1 | 15" TFT color touchscreen with Ethernet and USB interfaces. White front panel. JMobile runtime. |
| eTOP515-Silver | +ETOP515U2P1 | 15" TFT color touchscreen with Ethernet and USB interfaces. Silver front panel. JMobile runtime. |
| eTOP515-Black | +ETOP515U3P1 | 15" TFT color touchscreen with Ethernet and USB interfaces. Black front panel. JMobile runtime. |
| PROTFOIL-15-GL | R-PROT16 | Disposable protection foil for 15" widescreen eTOP touch panels (10 pieces). |
| PROTFOIL-15-UV | R-PROT22 | Disposable protection foil for 15" widescreen eTOP touch panels (10 pieces). UV resistant. |