



LIGHT BEYOND VISION

SENSORS
INCORPORATED

507 Kelsey Street • Delano, MN 55328
Phone 763-972-1040 Fax 763-972-1041
Toll Free 888-920-0939
Sensorsincorporated.com



WORLD'S LARGEST SELECTION

www.metaphase-tech.com

About



Metaphase Technologies offers the world's largest selection of machine vision and specialty LED Illumination. Since 1993, our engineering expertise in designing for integration into vision systems has enhanced a vast array of products. Metaphase illumination for industrial applications such as automation systems, line scan inspection, and fast-capture imaging strobe gives an edge to our customers in manufacturing and quality assurance. Most recently we've expanded our scope to develop illumination for security applications such as border patrol, law enforcement, and military markets.

Metaphase engineers develop lighting for commercial applications through our sister company, LED Living Technology. They are leading the industry into the future with their GEN2 Claris retrofit Flexkits.



Our award winning innovation has been recognized by The White House, our peers, and local business associations. We offer free testing and encourage you to bring your most challenging applications for a custom solution today. We stand by our credo, Lighting Excellence Delivered for customer Satisfaction!

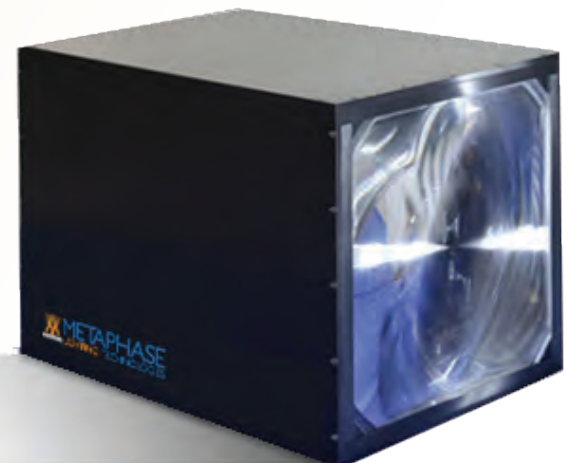

VisionSystems
DESIGN
2015 Innovators
Awards

PRODUCT SPOT LIGHT

LINE SCAN

Line and Advanced Illumination for Line Scan systems & cameras. Perfect for imaging continuous webs, and other high-speed line scan applications requiring ultra-high intensity and uniformity.
See pages 2-7

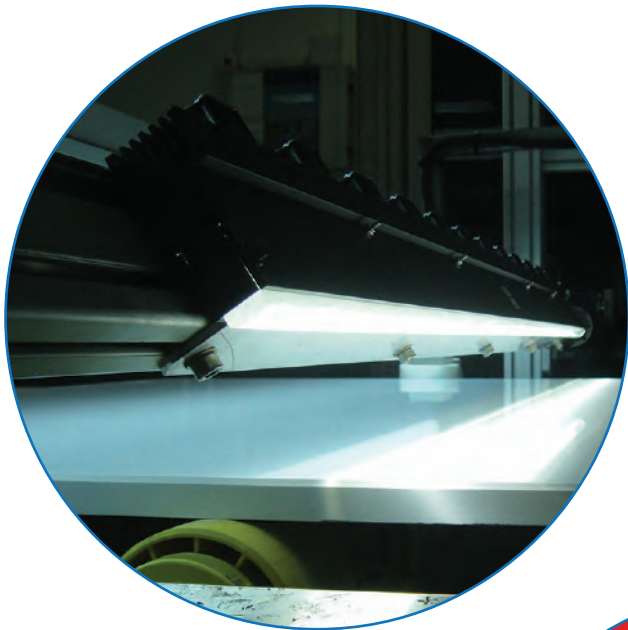

AREA SCAN

Area Scan Lighting for use with area scan cameras. Our wide variety of lights are perfect for multiple applications and lighting techniques.
See pages 8-17



SECURITY LIGHTING

Lights designed for security and law enforcement industries. A wide variety of applications are used to register compliance or anomalies in identifying breaches.
See Pages 20-21



LINE LIGHTS

FOR LINE SCAN

NEW INNOVATIONS HIGHER QUALITY UNIFORMITY

WHY LINE LIGHT

Front and Back Line Lights

Traditional line light like the Metaphase UL and MetaBright series are the preferred illumination for line scan applications. The narrow, structured beam delivers high intensity and concentrated light for the narrow field of view of a traditional line scan camera. Intensity and uniformity are vital to producing proper part illumination. Most line scan applications are high-speed with low exposure times and insufficient light levels prevent the camera from acquiring a usable image.

Visible Light and the Power of RGB Control

As with conventional vision systems, the color of light provided by the line scan illumination system can have a huge impact on image contrast and rendering. 6000K (degrees Kelvin) visible white light, currently the most popular choice, is neutral and great for enhancing product detail. A close second is the warmer 3000K, suitable for applications requiring high color rendering index (CRI) for accurate color rendering and accuracy. Although visible white light is popular and flexible, the use of specific wavelengths (colors) can often improve contrast and feature extraction. For example, the use of red (620-750nm) light enhances blue text (the complement of red) on an object, enhancing the contrast and making the text more readable. This technique is frequently used in the printing and packaging industries. Metaphase manufactures variable RGB line lights, whose output can be quickly and easily changed from any of its individual components (Red, Green, Blue).

Nonvisible, Near IR Lighting

Near IR illumination has garnered significant popularity with the increased use of security cameras. Near IR illumination produces very high apparent brightness at lower power levels across significant distances. This technology has been adopted for line scan applications. Reasons to use near IR include, the invisibility (to humans) of near IR wavelengths (850nm, 880nm, 940 nm), and that the camera sensor chips have reasonable sensitivity in this range. Note that silicon, hence most types of glass, is invisible to near IR. So, special lenses must be employed to properly focus the light onto the camera sensor. Some inks are also rendered invisible to near IR. Because near IR utilizes a single wavelength, it is intensity-based (rather than color-based). Thus, near IR is particularly useful when color variations need to be ignored on web applications, such as printing and rolling metal stock.

UV Lighting

UV (365nm, 395nm) has seen huge strides and very large up ticks in market penetration over the last few years. High intensity and tight focusing of the line scan illumination optimize the output of the UV LEDs. This illumination then excites UV-sensitive material or is absorbed, releasing visible light, often either blue or green depending on the material and excitation wavelength.

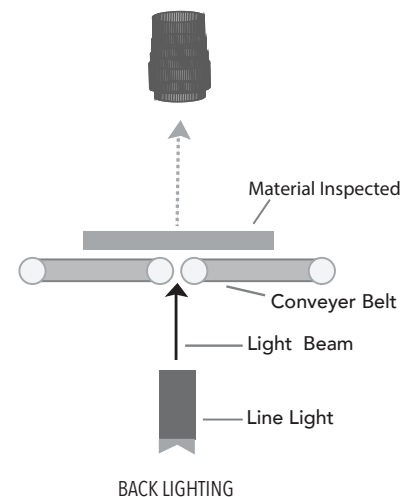
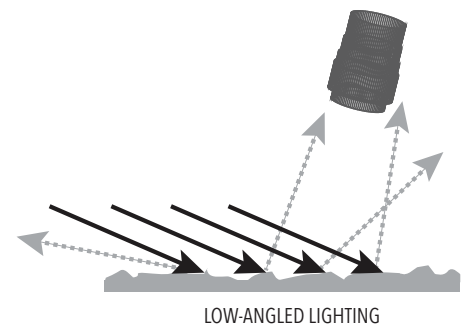
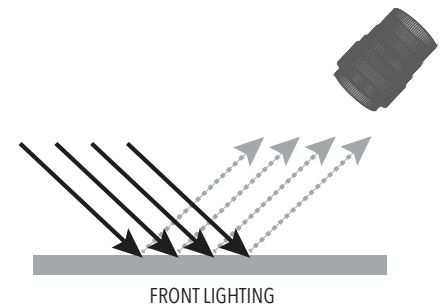

THE BEST KEEPS GETTING BETTER

▶ The UL Line Light is available in a wide variety of LED colors such as White, Red, Green Blue, IR, UV (365nm & 395nm), and even RGB with independent color control up to 150" (3.81m) in length for large web applications.

UL Line Lights

Blending the advanced breakthrough technology of our Gen4 Line Light with the compact design of our Meta-bright™ Line Light, UL Line Light is the latest line light design in the Metaphase family.

Its narrow, structured beam delivers high intensity and concentrated light for the narrow field of view of a traditional line scan camera. The high intensity and uniformity allows the UL Line Light to be used as a front light to inspect for material defects, angled to obtain an off-axis effect to highlight surface defects, or it may be placed beneath the object for a backlight effect to inspect for holes, voids, or contaminants.

The UL Line Light is available with a wide variety of LED colors such as white, red, green blue, IR, UV (365nm & 395nm), and even RGB with independent color control up to 150" (3.81m) in length for large web applications.



APPLICATION:

- Front lighting for webs and objects
- Back lighting for voids or transmission inspection
- Surface flaw detection



LINE LIGHTS

MetaBright™ Line Lights

Our classic MetaBright line light utilizes active fans for cooling to deliver intense and uniform lighting while keeping a tight heatsink profile. Metaphase offers the industry's breakthrough performance line lights for imaging, web, and high-speed line scan applications requiring ultra-high intensity and uniformity. Our line lights are built as lean fixtures that can be easily controlled and integrated into vision systems.

Our MetaBright™ Line Lights feature an adjustable lens and low current consumption.

The MetaBright™ Line Light is available with a wide variety of LED colors such as white, red, green blue, IR, UV (365nm & 395nm), and even RGB with independent color control up to 120" (3m) in length for large web applications.



APPLICATION:

Front lighting for webs and objects
Back lighting for voids or transmission inspection
Surface flaw detection

MetaLight™ Line Lights

MetaLight™ line lights are for applications that require a narrow strip of light at lower intensities than the MetaBright line lights. Thousands of these lights are currently being used in applications across the globe.

The MetaLight™ Line Light is available with a wide variety of LED colors such as white, red, green, blue and IR. And in size up to 80" (2m) in length for large web applications.



APPLICATION:

Front lighting for webs and objects
Back lighting for voids or transmission inspection
Surface flaw detection

HIGH UNIFORMITY HIGH INTENSITY

Collimated Line Light

Using Metaphase's propriety optics, the Collimated Line Light works similar to a traditional line light but can project its light at a lower divergence angle. This helps keep a tight, structured beam of light at longer working distance many meters away while delivering high intensity. This works great for applications where you can't have the light close to the object or web. This is useful creating clearance for robotics, imaging high tunnel ceilings (see image at right), create distance from hot objects, or applications requiring extremely precise backlight imaging. The Collimated Line Light is a great tool for any line scan or machine vision lighting application.

The Collimated Line Light is available with a wide variety of LED colors such as White, Red, Green Blue, IR, UV (365nm & 395nm), and even RGB with independent color control up to 150" (3.81m) in length for large web applications.

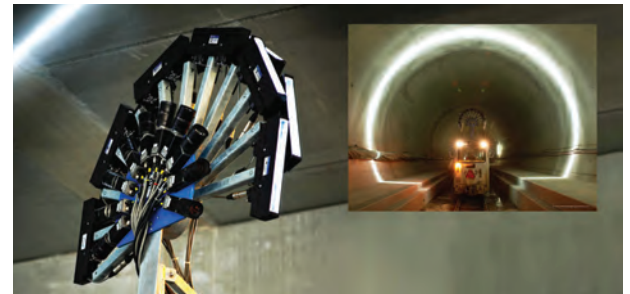

APPLICATION:

- Front lighting for webs and objects
- Back lighting for voids or transmission inspection
- Surface flaw detection

Target Distance (inches)	12	24	36	48	60	72
Line Width (inches)	.55	.7	1	1.2	1.5	1.8
Target Distance (cm)	31	61	91	213	152	183
Line Width (cm)	1.4	1.8	2.5	3.0	3.8	4.6

Custom beam width available upon request

Water Cooled & Compressed Air Line Scan Lights

Utilizing water cooling and compressed air, Metaphase can break down the thermal barriers of high end line scan application. The additional cooling allows us to push our line scan illumination to the extreme. Whether it's to provide a lighting solution in high ambient environment or pushing the envelope of extreme performance and intensity, our Metaphase Liquid & Compressed air cooled lights are an industry leader!

APPLICATION:

- High ambience
- Extreme intensity



Compressed Air Cooled HP-CDT

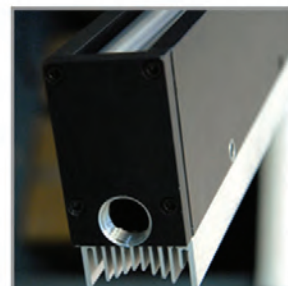

Water Cooled UL Line Light

ADVANCED LINE

▶ LINE SCAN

Compact Diffuse Tube Line Light

The Metaphase Compact Diffused Tube Line Lights (CDT) are one of the best kept secrets in Line Scan. They are our diffused tube light with aperture designed for line scan applications. Its diffused and multi-directional light output makes this light ideal for inspecting highly specular applications. The CDT allows you to see beyond clear plastic and images the product with minimal glare and feedback from the plastic wrap. With its highly diffused light output you can image metallic materials and curved items, such as gel tablets, with minimal glare or hot spotting.

The Compact Diffuse Tube Line Light is available with a wide variety of LED colors such as White, Red, Green Blue, IR, UV (365nm & 395nm), and even RGB with independent color control up to 80" (2m) in length for large web applications.



NWHP-CDT (Narrow Body)



HP-CDT (Wide Body)

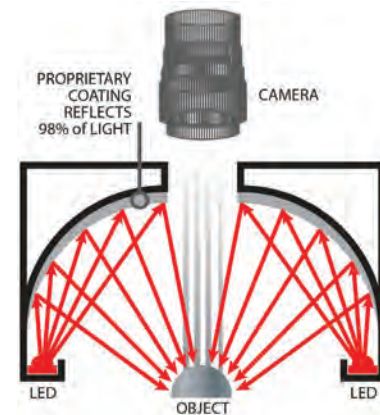

APPLICATION:

- Reflective mirror-like surfaces
- Metallics
- High-gloss finishes
- Curved or round objects

Diffuse Axial Line Lights

Using beam-splitter technology, Metaphase's Diffuse Axial Line Light (DALL) produces co-axial illumination, reflecting along the line of the camera aperture in line scan applications. The Diffuse Axial Line Light supports an unintrusive lighting scenario that can be configured to illuminate both wide and narrow fields of view and is ideal for applications involving highly reflective surfaces.

The Diffuse Axial Line Light is available with a wide variety of LED colors such as white, red, green, blue, IR, UV (365nm & 395nm), and even RGB with independent color control.

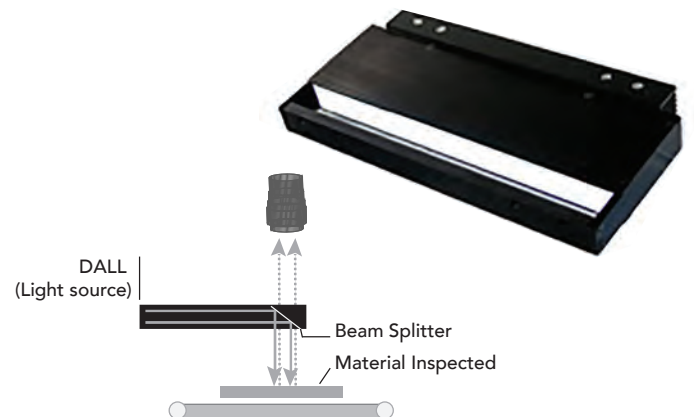

APPLICATION:

- Application requiring light and camera to be on-axis
- Product with variable heights
- High-speed bar code reading
- PCB inspection

SCAN LIGHTING

▶ LINE SCAN

Oblique (Dark Field) Line Light

Metaphase Oblique and Wrinkle Line light is designed with unique angled LEDs to project light at a 20 degree angle. The angled light makes the OLL great for creating a dark field/off-axis effect for line scan and area scan applications or for wrinkle detection. Using high output LED technology, the Oblique/Wrinkle Line light produces high intensity lighting needed for high speed imaging.

The Oblique (Dark Field) Back Light is available with a wide variety of LED colors such as White, Red, Green Blue, IR, UV (365nm & 395nm), and even RGB with independent color control up to 120" (3m) in length for large web applications.

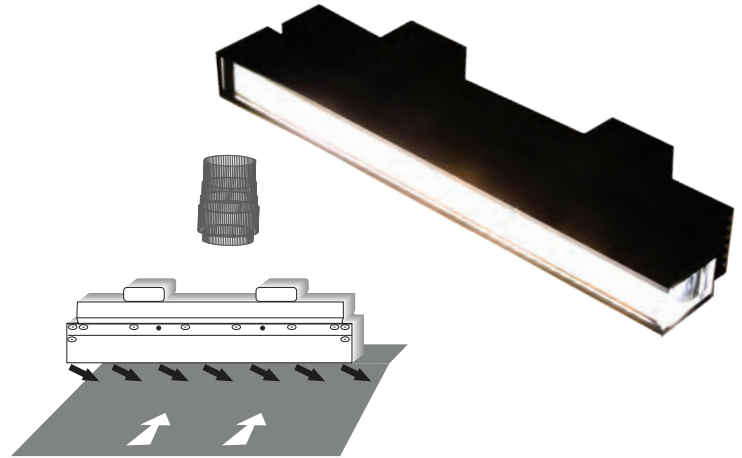

APPLICATION:

Cross machine direction Dark Field for flat materials such as cloth, plastics, or even coiled steel.

The Eclipser™ - Dark Field Back Light

Patent Pending Dark Field Back Light never before offered to the industry. Combining strategically positioned LED lights on innovative dark strips and newly developed light ray forming optics allows discovery of previously overlooked flaws in optically clear glass and plastic Quality Control systems. Bending light encircles particles and air pockets creating a glow illuminating the imperfection that can now be seen on a sub-pixel level.

The Eclipser™ - Dark Field Back Light is available with a wide variety of LED colors such as white, red, green, blue, IR, UV (365nm & 395nm), and even RGB with independent color control up to 120" (3m) in length for large web applications.



APPLICATION:

Transparent parts such as glass or extruded or molded plastic.

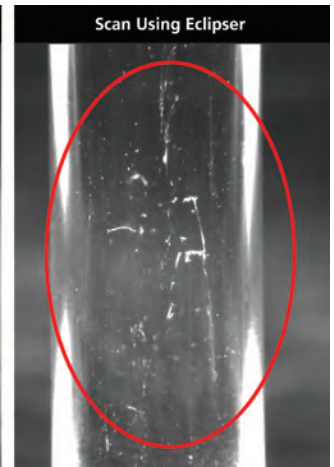
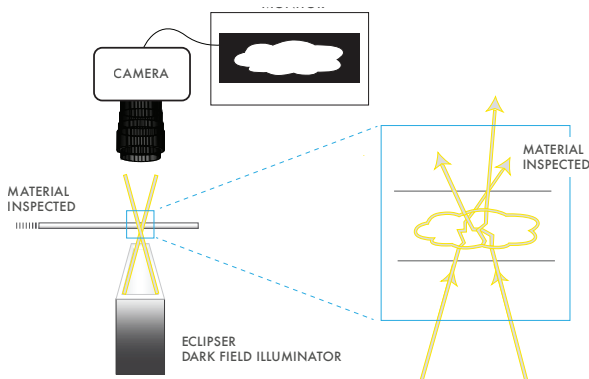

AREA SCAN

HIGH INTENSITY & UNIFORMITY

WHY AREA LIGHT

A robust area scan machine vision system utilizes local illumination as opposed to relying on ambient lighting. As the name implies, area scan illumination covers an x,y area being viewed by the matrix camera (unlike line scan illumination which covers a thin line being viewed by the single pixel row line scan camera.) Like all machine vision applications, the objective is to maximize the contrast between the features of interest and the background. Depending on the object or scene, different illumination techniques are utilized. For applications where the object's movement speed requires a very short, high intensity illumination in order to obtain a crisp, non-blurred images, the illumination is strobed with power-boosting (overdriving).

Area Scan Lighting Techniques

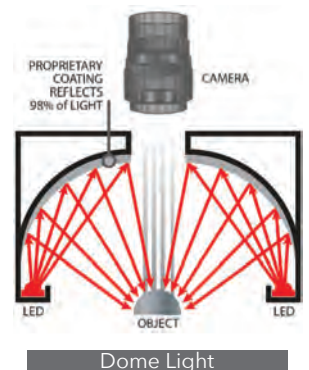
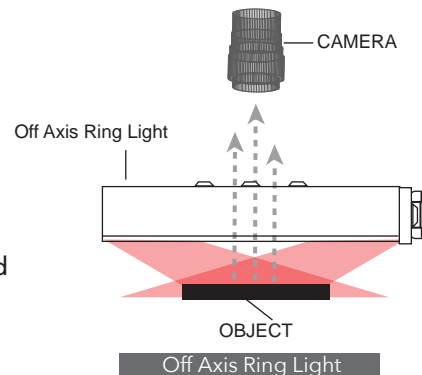
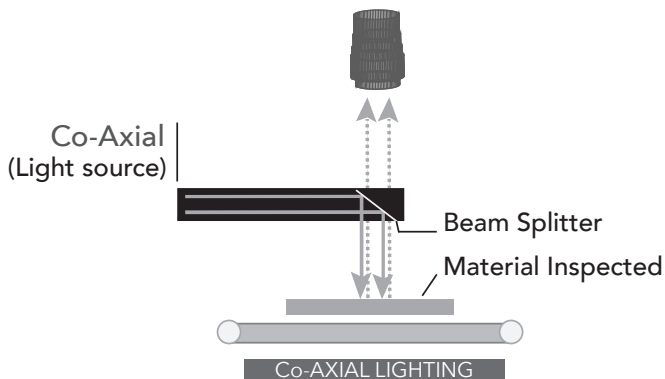
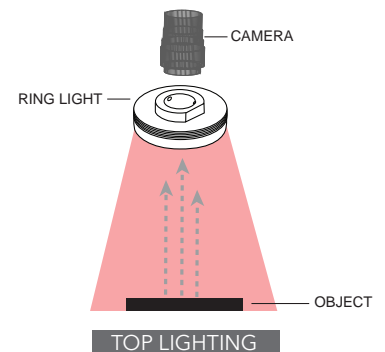
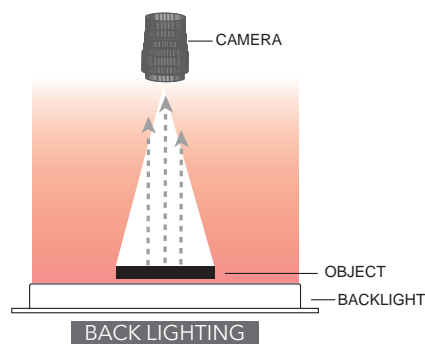
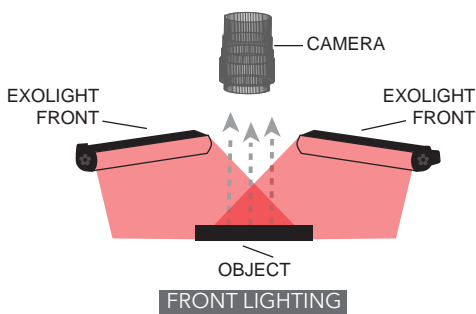

EXOLIGHT SERIES HIGH PERFORMANCE LINEAR BAR LIGHTS

▶ EXOLIGHT

Exolight (Fluorescent Replacements)

ExoLight™ series of LED illuminators are direct replacements of typical high frequency fluorescent tube lights historically used in machine vision applications. These lights use patented technology providing illumination 3X brighter than a fluorescent lamp. These low cost lights have a built-in constant current source driver so no special power supply is required to operate.

The Exolight is available with a wide variety of LED colors such as white, red, green, blue, IR, UV (365nm & 395nm), and even RGB with independent color control up to 120" (3m) in length for large web applications.

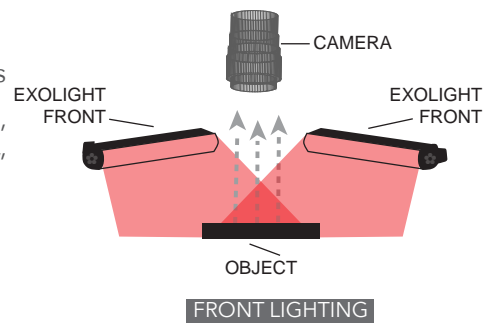

- APPLICATION:**
- Automotive
 - Medical
 - Electronics
 - Robotics
 - Agricultural
 - Sorting Facilities
 - Bar Code Reading
 - Transportation

Exo v2.0 Yes its LED!!!

Our brand new 2nd generation Exolight builds upon the world renowned, ground breaking technology of the original Exolight Series. Our new molded Lumiform diffuser provides a dramatic increase in uniformity, coverage area, and resistance to impact. With a 130 degree spread of uniform lighting, the Exo v2.0 is perfect for even the most sensitive area scan application and its high level of diffusion makes it a great candidate for transmission or backlight applications; even for Line Scan! Hard molding makes the diffuser extremely durable to impact and can be configured for IP rating with greater water and dust resistance. The Exo v2.0 is just another example of the Best Getting Better!

The Exo v2.0 is available with a wide variety of LED colors such as white, red, green, blue, IR, UV (395nm), and even RGB with independent color control up to 144" (3.6m) in length for large web applications.

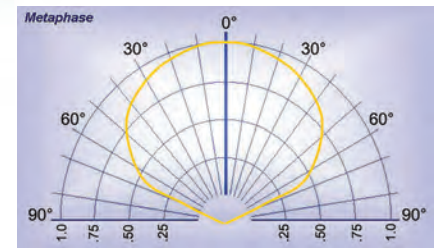
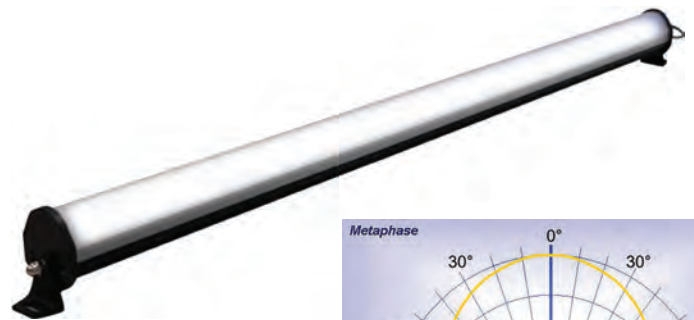

- APPLICATION:**
- Automotive
 - Medical
 - Electronics
 - Robotics
 - Line Scan Lighting
 - Agricultural
 - Sorting Facilities
 - Bar Code Reading
 - Transportation
 - Line Scan Lighting

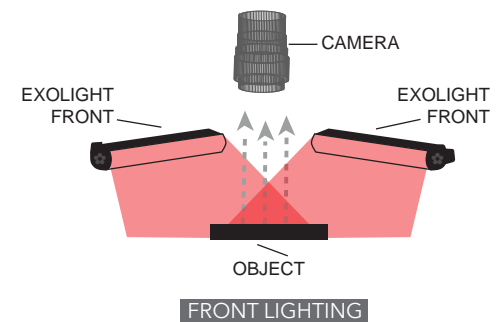

AREA SCAN:

► DOME ILLUMINATION

Flat Dome/Omni Light

The new MetaBright™ OmniLight flat dome from Meta-phase combines the best of our MetaBright™ technology with the enhanced and ultra-uniform lighting output of our newest TIR diffuser. Our lightweight alloy housing comes with welded brackets for secure and easy mounting. These lights are ideal when you need a diffused light source for close up inspection but can't fit in a traditional dome light. The Flat Dome/Omni Light is available with a wide variety of LED colors such as white, red, green, blue, IR, UV (395nm & 365nm), and even RGB with independent color control with sizes between 6"X6" up to 28"X32"

APPLICATION:

Application requiring light and camera to on-axis and/or the products height varies.
High-speed bar code reading
PCB inspection

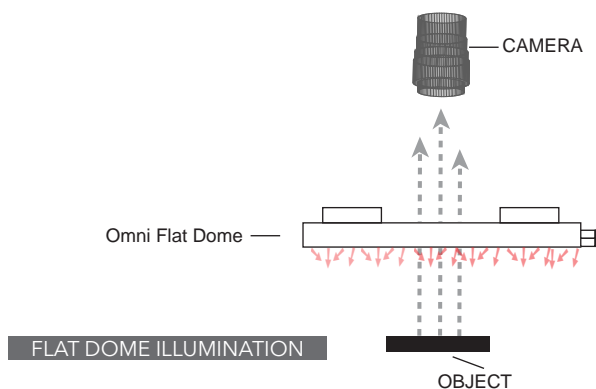

Diffuse Dome & Tube Lights

These special illuminators provide intense, evenly diffused illumination. Ideal for highly reflective, specular objects. Current dome lights range in size from 3" to 40" (.0762 meters to 1.016 meters) OD. Tubular shaped dome lights, often used in web applications, such as tablet blister pack inspection, are available in lengths of 12" to 36" (.3048 meter to .9144) meters. The Diffuse Dome & Tube Lights are available with a wide variety of LED colors such as white, red, green, blue, IR, and UV (365nm & 395nm). Sizes to 40" O.D. (dome) & 56" long (tube).

APPLICATION:

Application requiring light and camera to on-axis and/or the products height varies.
High-speed bar code reading
PCB inspection



AREA SCAN:

▶ RING LIGHT

MetaBright™ Ring Light

This MetaBright™ 3" O.D. (1" I.D.) high power near axis ring light provides extreme intensity lighting for optimal working distance of 2 inches. Our ring lights can be configured for wavelength and other specifications.

The MetaBright™ Ring Light is available with a wide variety of LED colors such as white, red, green, blue, IR, UV (395nm), and even RGB with independent color control. In sizes up to 2" O.D. TO 6" O.D.

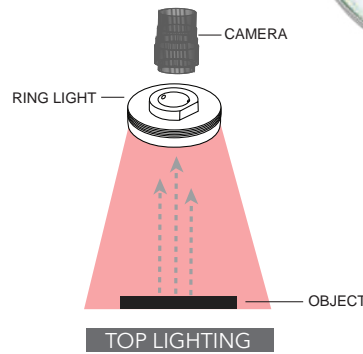

APPLICATION:

Electronic and circuitry inspecting	Food
Robotic vision and Automation	Drug
Pick and Place Machines	Medical
Bar Code Reading	Outdoor

Off Axis Ring Light (OARL)

This MetaLight™ 1" I.D. off-axis ring light (dark field) provides a near horizontal plane of light which is useful for highlighting surface defects, illuminating specular surfaces, and side lighting prominent target features. Our ring lights can be configured for wavelength and other specifications.

The Off-Axis Ring Light is available with a wide variety of LED colors such as white, red, green, blue, IR, UV (395nm), and even RGB with independent color control up to 1" I.D. to 10" I.D. sizes

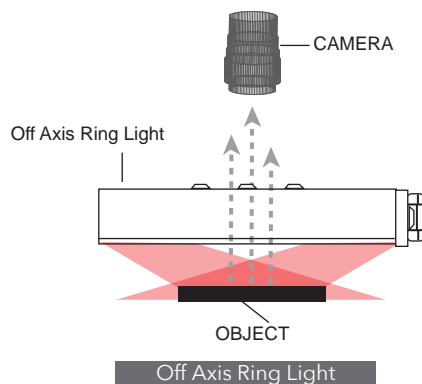
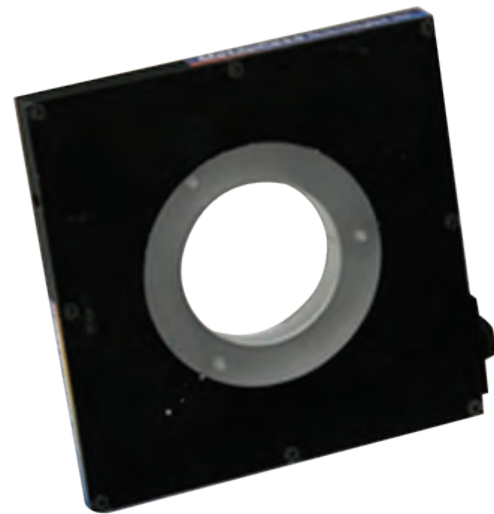

APPLICATION:

Surface defects such as raises or digs
For Highlighting edges or raised edges of parts

AREA SCAN:

▶ WASHDOWN & HARSH ENVIRONMENT

RoboLights:

MetaBright™ RoboLights provide high intensity direct illumination comparable to MetaBright™ Front Lights and are designed for IP67 rated environments. Robolights feature rugged industrial housings for industrial robotics work envelopes. The Robolight is a cost effective and “integrator ready” machine vision illuminator with a connectorized 24VDC power and on-board, integrated driver.

The Robolight is available with a wide variety of LED colors such as white, red, green blue, IR, UV (395nm), and even RGB with independent color control up to 120” (3m) in length for large web applications.



APPLICATION:

Large Work Envelopes	Liquid Filling
Packaging Food & Drugs	NEMA 4X
Wet Locations	
Washdown Applications	

Washdown Ring Light

Our IP67 Washdown and Harsh Environment Near Axial and Bright Field Ring Lights allow you to use one of the most popular lighting systems in a larger variety of environments. These Ring Lights can now be used where they may be exposed to water, moisture, and debris. With this watertight gasket design, high-pressure jets and wash downs are no problem; great for food, drug, or outdoor applications. The MetaBright Washdown Ring Light is available with a wide variety of LED colors such as white, red, green, blue, IR, UV (365 nm and 395 nm), and RGB with independent color control. With sizes ranging from 2” O.D. to 6” O.D.

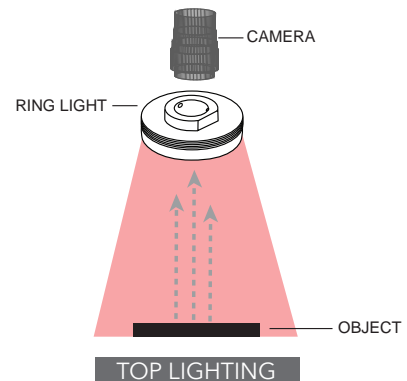
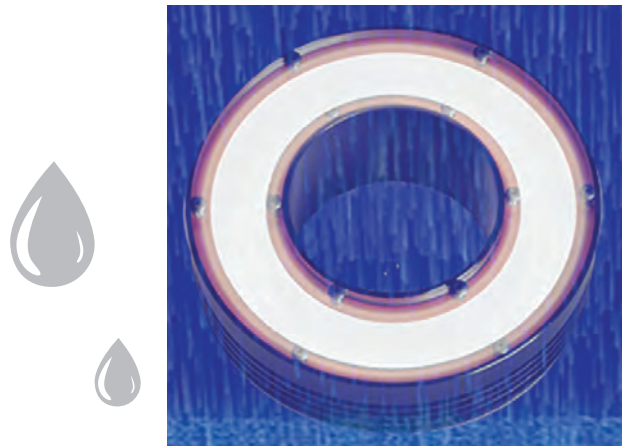

APPLICATION:

Electronic and circuitry inspecting	Food
Robotic vision and Automation	Drug
Pick and Place Machines	Medical
Bar Code Reading	

AREA SCAN:

▶ HARSH ENVIRONMENT & WASHDOWN

Washdown Front Light 300x150

This washdown ruggedized MetaBright™ area front light provides 11" x 6" (300x150mm) direct intensity lighting. Used alone or in pairs these lights have the advantage of being able to be positioned for on and off axis illumination. The MT-FL300X150 is available with a wide variety of LED colors such as white, red, green, blue, & IR.

APPLICATION:

Flood Lighting
Outdoor Applications



Washdown Back Light

The MetaBright Series is a high performance and uniform light source for silhouetting and transmissive application. The IP67 Washdown Backlights can be used where they may be exposed to water, moisture, and debris. With the watertight gasket design, high-pressure jets and wash downs are no problem; great for food, drug, or outdoor applications. Using a full array LED layout, we can pack more LEDs per square inch to provide greater intensity, uniformity, and performance. The MetaBright Backlight Series is available with a wide variety of LED colors and sizes such as white, red, green, blue, IR, UV (365 nm and 395 nm) and RGB with independent color control with active areas ranging from 1"x1" (25mm x 25mm) to 5'x 5' (1.5m x 1.5m) in aluminum or stainless configurations.

APPLICATION:

Silhouette
Transmissive Imaging
Washdown

Food
Medical

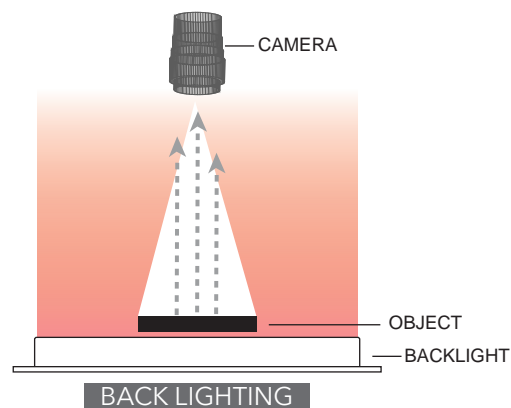

AREA SCAN:



▶ WASHDOWN & HARSH ENVIRONMENT

Washdown Off-Axis Ring Light (OARL)

The Metaphase Washdown Off-Axis Ring light (OARL) takes our proven Off-Axis ring light and puts it into a washdown and harsh environment configuration. Our washdown OARL can now be used where they may be exposed to water, moisture, and debris. With this watertight gasket design, high-pressure jets and wash downs are no problem; great for food, drug, or outdoor applications. The off-axis ring light (dark field) provides a near horizontal plane of light which is useful for highlighting surface defects, illuminating specular surfaces, and side lighting prominent target features. Our ring lights can be configured for wavelength and other specifications.

The Washdown OARL Ring Light is available with a wide variety of LED colors such as White, Red, Green, Blue, IR, UV (365 nm and 395 nm), and RGB with independent color control with sizes from 1" I.D to 8" I.D.

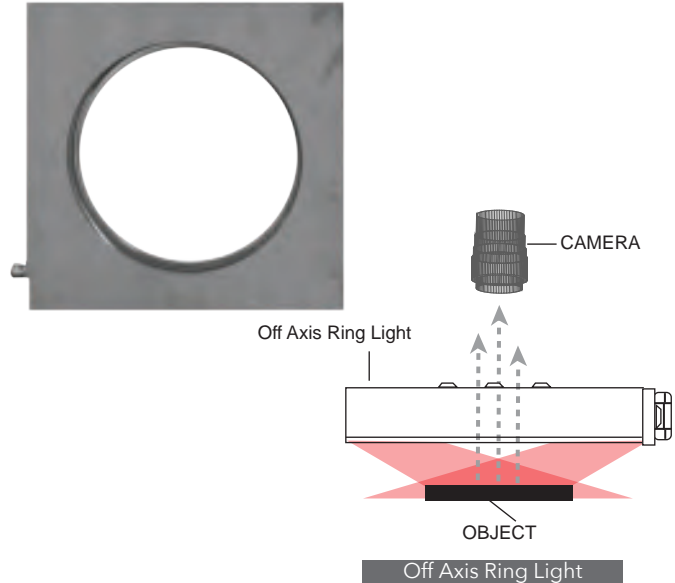

APPLICATION:
Surface defects such as raises or digs
For Highlighting edges or raised edges of parts

Washdown Spotlights

Metaphase's new LED Spot Light provides low cost, wash-down illumination. These new illuminators are available in a variety of beam angles and optimal working distances. These lights are housed in rugged waterproof housing that can stand up to high pressure washdown environments. The standard Spot light has a coverage area of 8ft at a distance of 8ft; other angles include: $\pm 12^\circ$, $\pm 16^\circ$, and $\pm 25^\circ$. Unlike fluorescent spotlights, these LED based illuminators have a long lifetime and will not degrade over time. These efficient lights consume only 11 watts of power, yet shine 6 times brighter than 60watt incandescent. Thanks to Metaphase's built-in constant current source driver for complete LED light control, a technology Metaphase has installed and perfected for the last five years, no expensive external current driver is required. The lights include an adjustable locking mounting bracket.



APPLICATION:
Spot Lighting
Washdown Applications



MISCELLANEOUS

▶ SPOT LIGHT

Round Area Front Lights (RAL)

This RAL light provides direct intensity lighting. Used alone or in pairs these lights have the advantage of being able to be moved around to both on and off axis to provide the best lighting scenario. Our front lights can be configured for wavelength and other specifications.



APPLICATION:

Pick and Place	High Speed QC
Micro Defects	Small Space Apps
Inspection of Black with low diffusion properties	

LED Pattern Projector (LPP)

The LED Pattern projector projects a variety of patterns at different working distances. Paired with a lens and pattern reticle, the LED pattern projector is ideal for structured light applications. The device intensity can be controlled with a 0 ~ 10V intensity control signal. Using 10 watt LED technology, we can push out more intensity without the danger of laser.

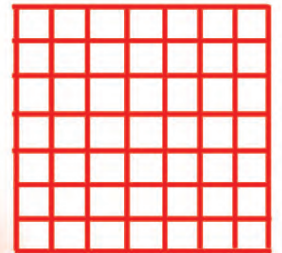

STANDARD PATTERN

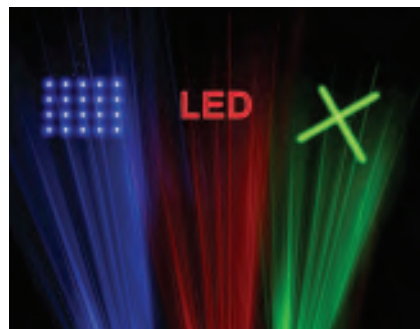
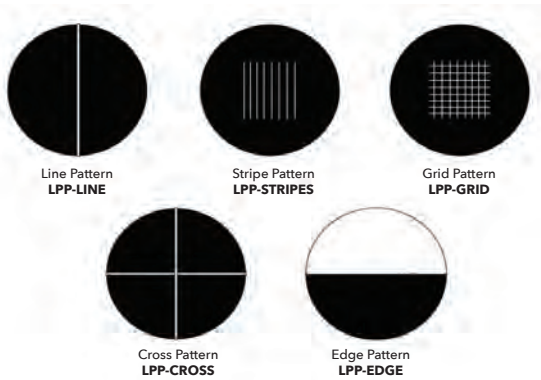

APPLICATION:

Pick and Place	High Speed QC
Micro Defects	Small Space Apps
Inspection of Black with low diffusion properties	

AREA SCAN:

▶ BACKLIGHTS

MetaBright™ Backlights

The MetaBright Series is a high performance and uniform light source for silhouetting and transmissive application. Using a Full Array LED layout, we can pack more LEDs per square inch to provide greater intensity, uniformity and performance. The MetaBright Backlight Series is available with a wide variety of LED colors and sizes such as White, Red, Green, Blue, IR, UV (365 nm and 395 nm) and RGB with independent color control with active areas ranging from 1"x1" (25mm x 25mm) to 5' x 5' (1.5m x 1.5m).

APPLICATION:

Silhouette
Transmissive Imaging

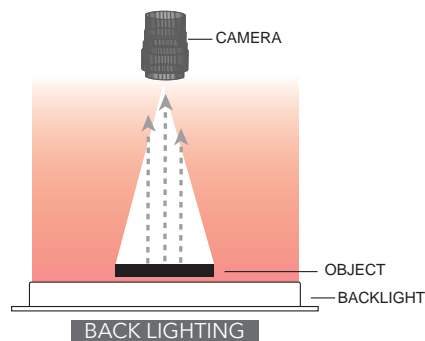

MetaBright™ Thin Backlights

The Thin Backlight Series is a high performance and uniform light source for silhouetting and transmissive application. With a housing thickness of less than 11mm and edge-to-edge lighting, the thin backlight series helps maximize illumination area in tight spaces. Using a Full Array LED layout, we can pack more LEDs per square inch to provide greater intensity, uniformity and performance. The Thin Backlight Series is available with a wide variety of LED colors and sizes such as White, Red, Green, Blue, IR, and UV (365 nm and 395 nm) with active areas ranging from 1"x1" (25mm x 25mm) to 5" x 10" (127m x 254m).

APPLICATION:

Silhouette
Transmissive Imaging

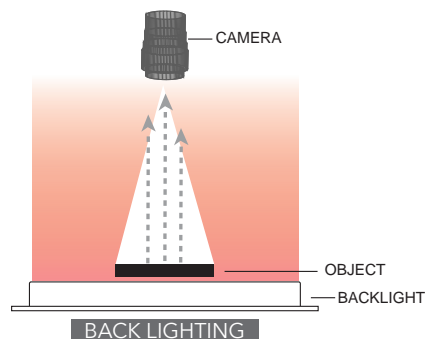

AREA SCAN:

▶ BACKLIGHTS

Economical Backlight

The MetaBright Series is a high performance and uniform light source for silhouetting and transmissive application. Using an edge-lit LED design, we can provide a uniform and economical backlighting solution. The Economical Backlight Series is available White or Red LEDs with active areas ranging from 3.5"x6" (89mm x 155mm) to 21" x 44" (533mm x 1118mm).

APPLICATION:

Silhouette
Transmissive Imaging

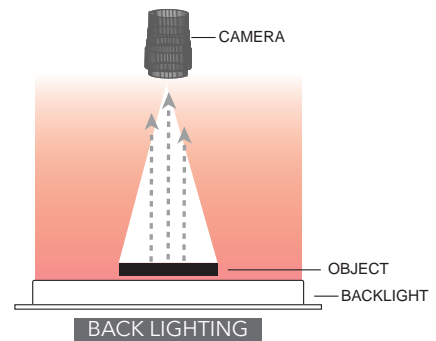
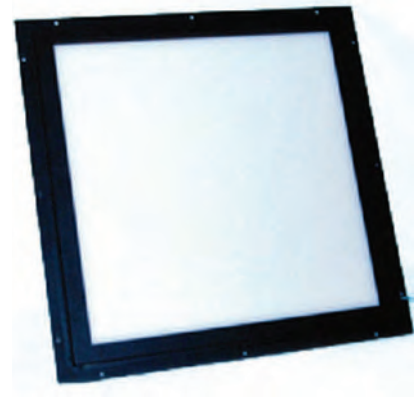

Collimated Backlight

The Collimated Backlight Series is a high performance, uniform, and Collimated light source for high precision silhouetting and transmissive application. Using Collimated optics, the light exits at a low divergent angle making it perfect for applications requiring high precision measurements and telecentric lens. Using a full array LED layout, we can pack more LEDs per square inch to provide greater intensity, uniformity and performance. The Collimated Backlight Series is available with a wide variety of LED colors and sizes such as White, Red, Green, Blue, IR, UV (365 nm and 395 nm) and RGB with independent color control with active areas ranging from 1"x1" (25mm x 25mm) to 3'x 3' (1m x 1m).

APPLICATION:

Silhouette
Transmissive Imaging

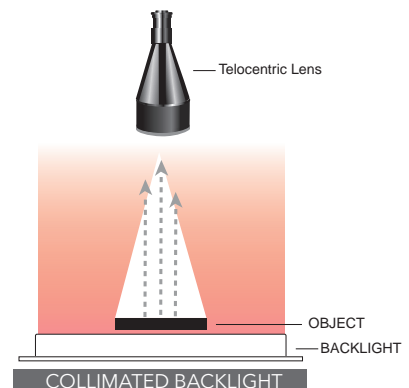
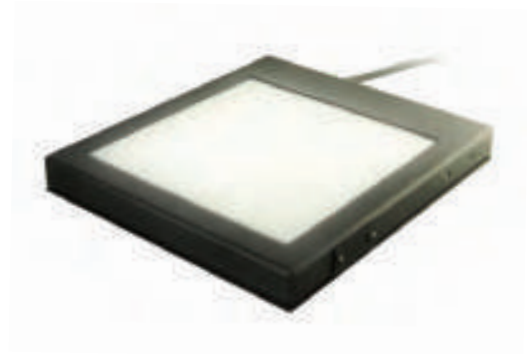

FIBER ILLUMINATION

▶ METAPHASER

The Metaphase Fiber Optic LED Illuminator provides intense illumination for fiber optic delivery systems. Metaphase Fiber Optic LED Illuminator includes various nose pieces for mating the fiber light guide to the supply. Nose pieces include a Universal nose piece with optional adapters to mate to a wide variety of fiber tip diameters and individual nose pieces that are designed for specific fibers.

The fiber optic illuminator can be used with all the typical fiber and liquid light guides such as single fiber light guide, bifurcated, goose neck, backlight, diffused axial, ring, etc. This supply is an ideal replacement for Halogen based light supplies used in microscopy, endoscopy, machine vision, and applications which cannot have active components near the inspection zone.



APPLICATION:

Microscopy
Industrial Borescopes
Inspection Systems
Machine Vision

▶ MP-LED-150

These systems are compact in size, economically priced, and very simple to operate. Each system is factory calibrated and pre-aligned for a corresponding nose piece adapter that ensures compatibility for new and retrofit fiber based light systems. No optical adjustments are required.



APPLICATION:

Microscopy Architectural Fiber Lighting
Endoscopy Machine Vision
Spotlight source Fiber line Lights
Fiber Backlighting

LED CONTROLLERS & DRIVER TECHNOLOGIES

▶ ULC-2

Universal LED Controller (ULC)

Provides independent, constant-current control of two LED loads at up to 4 amps continuous DC and a maximum output power of 60 Watts per channel. In Pulse (Strobe) Mode, the ULC-2 is capable of output currents up to 40 amps. The ULC-2 is capable of driving LED forward voltages between 3V and 20V and higher, but with a possible reduction in maximum pulse current. Pulsewidths are adjustable down to 2 microseconds and external trigger rates up to 50kHz.



APPLICATION:

4 Amp continuous
40 Amps strobed

▶ DDC-3

Digital Dimming Controller (DDC) - 3 Channels

Metaphase Technologies' Digital Dimming Controller (DDC-3) provides 0-10V dimming true voltage control of three independent LED loads in increments of 0.1V. The DDC-3 may be remotely controlled over Ethernet using Metaphase Technologies' MetaBOSS Windows software or by third-party programs using the DDC-3's Ethernet Commands. Additionally, user-adjustments of the DDC-3 are provided by way of a user-friendly LCD interface.



APPLICATION:

RGB Control
Multi 0-10V Light Dimming

BUILT-IN DRIVER

Metaphase offers many of its lights with built-in driver and dimming control. This feature allows for stable and optimal LED illumination without the need for a separate controller.

IN-LINE OPTIONS

Metaphase offers in-line versions of both dimming and strobe control for space constraint applications. Using these in-line options, circuits are enclosed outside the light unit which allows for a more compact LED light.

BUILT-IN STROBE CONTROLLER

This space-saving feature provides "power boosted" (high current) strobe control of the LED illuminator that is actually built right into the LED light fixture itself. This built-in feature eliminates power loss from the cable to an external strobe controller.

IN-LINE DIMMER

The in-line dimming option offers a potentiometer intensity control. Simply requires supply voltage for the light.

IN-LINE STROBE

No external strobe controller is required, only voltage and trigger signal for the light to strobe required.

LIGHT BEYOND

AWARD WINNING

High Speed LED Illuminator System

Utilizing the latest in LED optics and strobe controller technology, the Award Winning High Speed LED Illuminator (HiSLED) provides the ultra-high intensity illumination at the short pulses required to capture non-blurred images of high speed events. Traditionally this required costly high speed cameras with high amount of illumination but now can be accomplished more economically utilizing the HiSLED Illumination System.

The HiSLED is available with a wide variety of LED colors such as White, Red, Green Blue, IR.



APPLICATION:

- Image speed projectile analysis
- Mechanical machine diagnostics
- Military munition / armament analysis
- Bullet flight imaging

▶ LAW ENFORCEMENT LIGHTING

Long Range Strobe Light

Replaces Xenon strobes. Self contained strobe light in a compact 6" x 6" x 2.5" (approx) ABS all weather housing with optional powder coated light hood. Bottom side mount sealed connector and stainless steel mounting hardware allows it to be attached to customer's own bracket or Pelco style swivel base (sold separately).

The Long Range Strobe Light is available with a wide variety of LED colors such as White, Red, Green Blue, IR.



APPLICATION:

- ANPR (automated number plate recognition)
- Surveillance and security checkpoint control monitoring
- Large area industrial robotics and pallet loading stations
- Stop motion video
- High speed photography
- Night vision surveillance

VISION

Security Light

Customized high performance version of our long range strobe light replaces Xenon strobes. It is built for the harshest environments and comes with ABS all weather housing with optional powder coated light hood. The bottom side mount sealed connector and stainless steel mounting hardware allows it to be attached to customer's own bracket or Pelco style swivel base (sold separately).

The Security Light is available with a wide variety of LED colors such as White, Red, Green Blue, and IR.



APPLICATION:

- ANPR (automated number plate recognition)
- Surveillance and security checkpoint control monitoring
- Large area industrial robotics and pallet loading stations
- Stop Motion video
- High speed photography
- Night vision surveillance

Explosive and Military Applications

Metaphase lighting is used in many military projects; often integrated into explosion-proof enclosures for volatile applications. For example, a hot-running inspection unit could ignite fumes during a gas tank inspection which are especially prevalent in the military. LED technology is perfect for this type of application because of its low heat output.

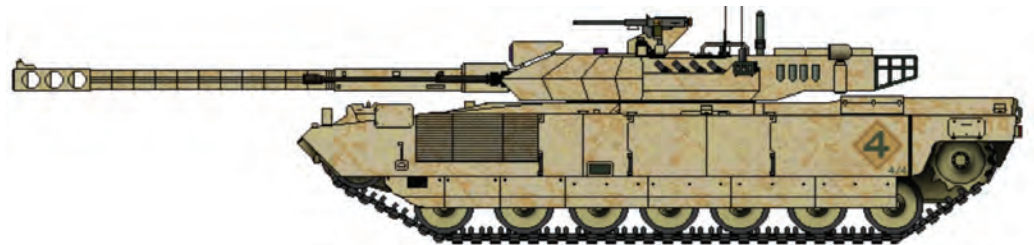

PRODUCTS DESIGNED AND BUILT EXCLUSIVELY IN THE USA



Over 20 years of innovative lighting experience. Several thousand lighting products for machine vision designed and manufactured in the USA.



Metaphase is awarded the Best Employer in Eastern Pennsylvania for 2015 by the governor of Pennsylvania.



In 2015, Oliver Szeto, president of Metaphase, along with other top CEO's of the nation, was invited by the White House to recognize his achievements, contributions, and commitment to the country.



Advanced LED lighting integrated into applications for life sciences, military, border control, security, microscopy, and the aerospace industries.



Our ground breaking High Speed LED lighting system (HiSLED) received the Innovation Award for 2015 from Vision Systems Design magazine.



Together with sister company, Led Living Technology, we've created one of the largest leading LED companies serving the industrial and commercial lighting industries.



Honored to receive the first Innovation award by the Chamber of Commerce in Pennsylvania.



211 Sinclair Rd, Suite 100
Bristol, PA 19007, USA
Tel: 215-639-8699
www.metaphase-tech.com



Check out our sister company for commercial lighting
www.ledlivingtechnology.com

