

Safety Switches with Separate Actuator, Metal Housing **EUCHNER**

Selection table for safety switches STA with guard locking and guard lock monitoring

Version									
standard		One actuating head made of metal							
TW		TWIN, 2 actuating heads made of metal							
Release feature									
HE		Mechanical release on the front							
FE		Escape release on the rear side							
Door monitoring									
STA3/4					With door monitoring contact				
STA1/2					Without door monitoring contact				
Connection									
W							Thread M20x1.5 for cable gland		
SR11							Plug connector 11-pin + PE		
RC18							Plug connector 18-pin + PE		
Version		Release feature		Door monitoring		Connection			Page
standard	TW	HE	FE	STA3/4	STA1/2	W	SR11	RC18	
●		●		●		●			108
●		●		●			●	●	109
●		●			●	●			110
●		●	●	●		●			111
	●	●		●		●			112



Safety switch STA with guard locking and guard lock monitoring

- ▶ Mechanical release on the front
- ▶ With door monitoring contact
- ▶ Plug connector optional



Approach direction



Horizontal and vertical
Can be adjusted in 90° steps

Mechanical release

Is used for releasing the guard locking with the aid of a tool. To protect against tampering, the mechanical release is sealed with sealing lacquer.

Solenoid operating voltage

▶ AC/DC 24 V +10%, -15%

LED function display (optional)

A function display (2 LEDs, red and green) is available for the following voltage ranges:

▶ AC/DC 24 V +10%, -15%

Guard locking types

- STA3** Closed-circuit current principle, guard locking by spring force. Release by applying voltage to the guard locking solenoid.
- STA4** Open-circuit current principle, guard locking by applying voltage to the guard locking solenoid. Release by spring force.

Switching elements

- ▶ **2131** Slow-action switching contact
2 NC ⊕ + 1 NO + 1 NC
(door monitoring contact)
- ▶ **4121** Slow-action switching contact
2 NC ⊕ + 1 NC / 1 NO
(door monitoring contact)
- ▶ **4131** Slow-action switching contact
2 NC ⊕ + 1 NO + 1 NO
(door monitoring contact)
- ▶ **4141** Slow-action switching contact
2 NC ⊕ + 2 NC ⊕
(door monitoring contact)

Cable entry M20 x 1.5

Dimension drawing

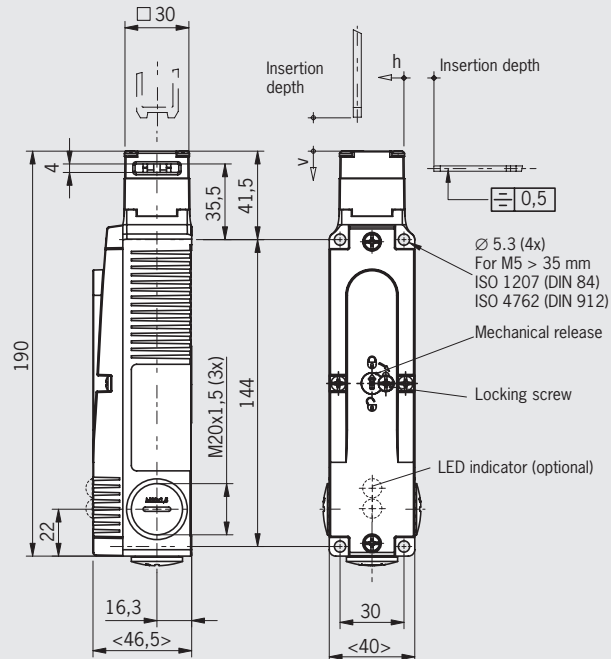

Please order actuator separately
(See Pages 124-126)

For cable glands see page 132

Wiring diagrams Actuator inserted and locked

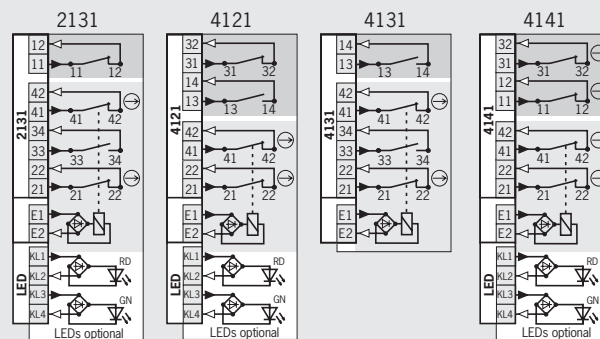

- Solenoid monitoring
- Door monitoring

For switching functions see technical data on Page 190

Ordering table

Series	Connection	Guard locking	Switching element	Version	Solenoid operating voltage	
					AC/DC 24 V	AC 230 V
STA	W Cable entry 3 x M20 x 1.5	3 Mechanical	2131 2 NC ⊕ + 1 NC + 1 NO	024L LED indicator AC/DC 24 V	096938 STA3A-2131A024M	104171 STA3A-2131A230M
					096936 STA3A-4121A024M	-
			4121 2 NC ⊕ + 1 NC / 1 NO	024L LED indicator AC/DC 24 V	106535 STA3A-4121A024L024M	-
					099480 STA3A-4131A024M	-
			4131 2 NC ⊕ + 1 NO + 1 NO	024L LED indicator AC/DC 24 V	099274 STA3A-4141A024M	-
					100898 STA3A-4141A024L024M	-
		4 Electrical	2131 2 NC ⊕ + 1 NC + 1 NO	024L LED indicator AC/DC 24 V	096939 STA4A-2131A024M	-
					103926 STA4A-2131A024L024M	-
			4121 2 NC ⊕ + 1 NC / 1 NO	024L LED indicator AC/DC 24 V	096937 STA4A-4121A024M	-
					099481 STA4A-4131A024M	-
			4131 2 NC ⊕ + 1 NO + 1 NO	024L LED indicator AC/DC 24 V	109172 STA4A-4141A024M	-
					-	-

Safety Switches with Separate Actuator, Metal Housing **EUCHNER**



Plug connector SR11 11-pin + PE

Dimension drawing

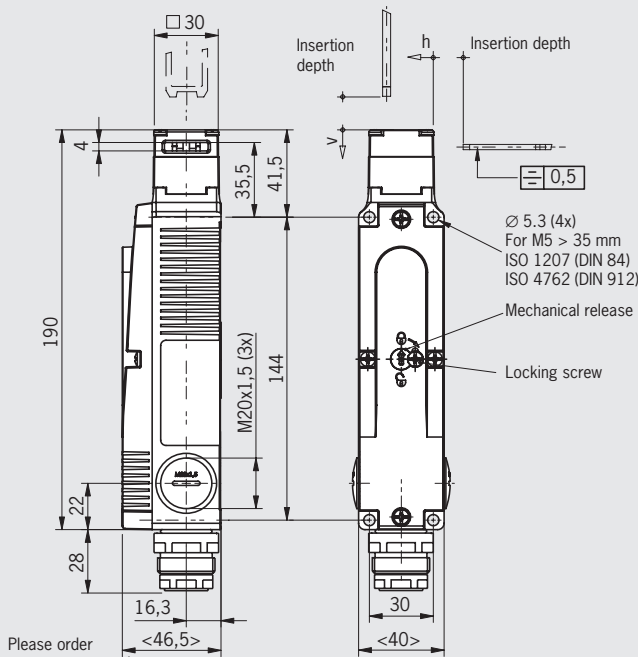

Please order actuator separately (See Pages 124-126)

For plug connectors see page 128

Plug connector RC18 18-pin + PE

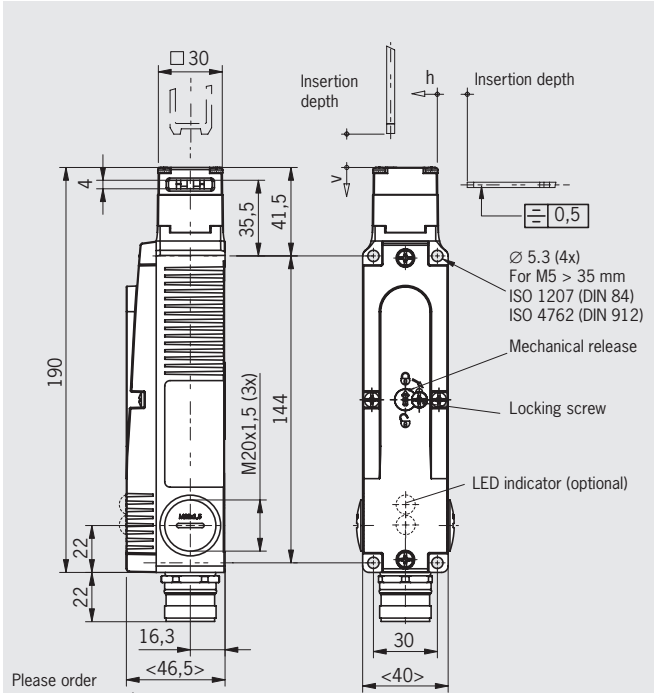

Please order actuator separately (See Pages 124-126)

For plug connectors see page 129

Wiring diagrams Actuator inserted and locked

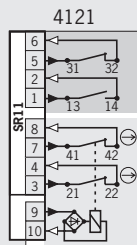

- Solenoid monitoring
- Door monitoring

For switching functions see technical data on Page 190

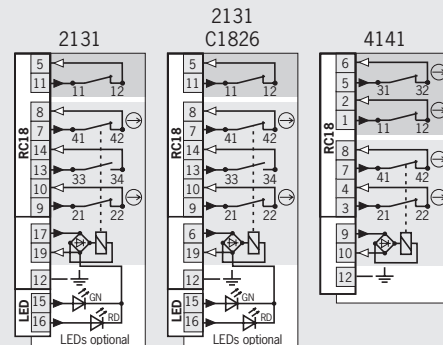

- Solenoid monitoring
- Door monitoring

For switching functions see technical data on Page 190

Ordering table

Series	Connection	Guard locking	Switching element	Version	Solenoid operating voltage	
					AC/DC 24 V	
STA	SR11 Plug connector	3 Mechanical	4121 2 NC ⊖ + 1 NC / 1 NO		105304 STA3A-4121A024SR11	
				024L LED indicator AC/DC 24 V	099658 STA3A-2131A024L024RC18	
	RC18 Plug connector	3 Mechanical	2131 2 NC ⊖ + 1 NO + 1 NC	024L LED indicator AC/DC 24 V	106623 STA3A-2131A024L024RC18C1826	
				C1826 Special wiring	100029 STA3A-4141A024RC18	
	RC18 Plug connector	4 Electrical	2131 2 NC ⊖ + 1 NC + 1 NO	024L LED indicator AC/DC 24 V	105303 STA4A-2131A024L024RC18	
				024L LED indicator AC/DC 24 V C1826 Special wiring	106622 STA4A-2131A024L024RC18C1826	

For safety precautions see page 197
For technical data see page 163





Safety switch STA with guard locking and guard lock monitoring

- ▶ Mechanical release on the front
- ▶ Without door monitoring contact



Approach direction



Horizontal and vertical
Can be adjusted in 90° steps

Mechanical release

Is used for releasing the guard locking with the aid of a tool. To protect against tampering, the mechanical release is sealed with sealing lacquer.

Solenoid operating voltage

- ▶ AC/DC 24 V +10%, -15%

Guard locking types

STA1 Closed-circuit current principle, guard locking by spring force. Release by applying voltage to the guard locking solenoid.

STA2 Open-circuit current principle, guard locking by applying voltage to the guard locking solenoid. Release by spring force.

Switching elements

- ▶ **4131** Slow-action switching contact
2 NC ⊖ + 2 NO

Cable entry M20 x 1.5

Dimension drawing

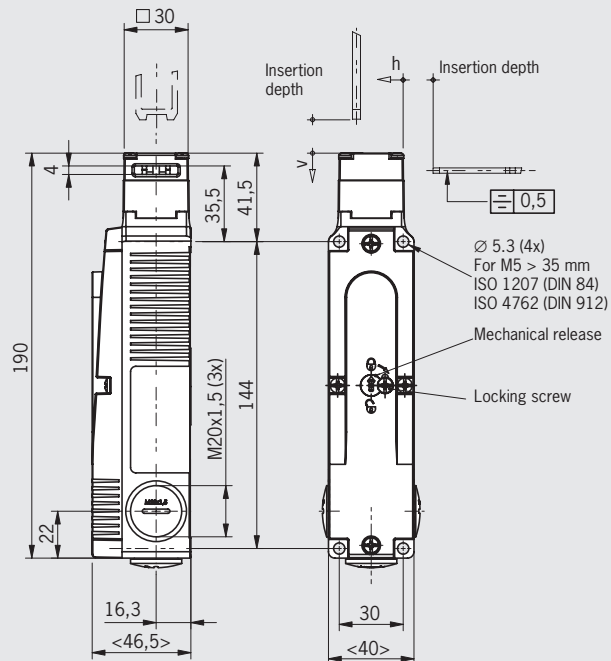

Please order actuator separately
(See Pages 124-126)

For cable glands see page 132

Wiring diagrams Actuator inserted and locked

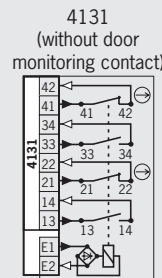

For switching functions see technical data on Page 190

Ordering table

Series	Connection	Guard locking	Switching element	Solenoid operating voltage	
				AC/DC 24 V	
STA	W Cable entry 3 x M20 x 1.5	1 Mechanical	4131 2 NC ⊖ + 2 NO	096439	STA1A4131A024M
		2 Electrical	4131 2 NC ⊖ + 2 NO	096935	STA2A4131A024M



Safety switch STA with guard locking and guard lock monitoring

- ▶ Escape release from the rear
- ▶ With door monitoring contact



Approach direction



Horizontal and vertical
Can be adjusted in 90° steps

Escape release

Is used for the manual release of the guard locking from within the danger area without tools. With identification of On/Off position..

Solenoid operating voltage

- ▶ AC/DC 24 V +10%, -15%

Guard locking types

STA3 Closed-circuit current principle, guard locking by spring force. Release by applying voltage to the guard locking solenoid.

Switching elements

- ▶ **2131** Slow-action switching contact
2 NC ⊖ + 1 NO + 1 NC
(door monitoring contact)

Cable entry M20 x 1.5

Dimension drawing

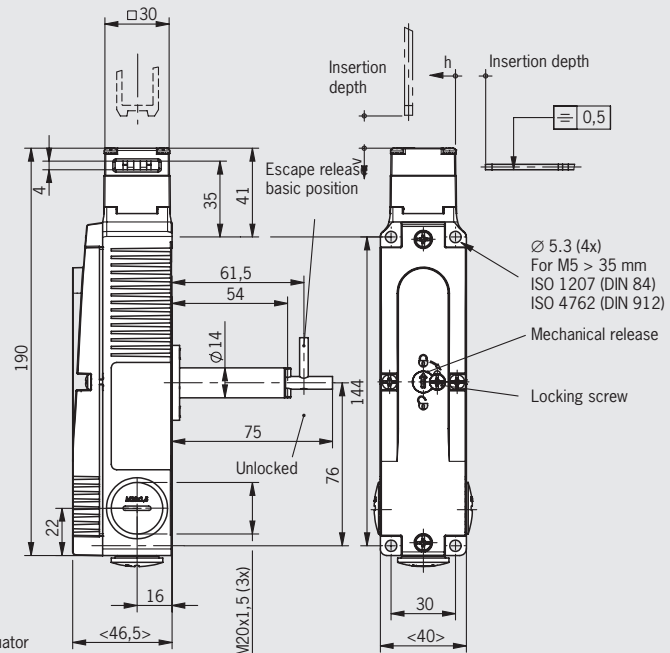

For cable glands see page 132

Wiring diagrams Actuator inserted and locked

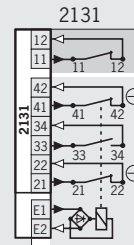

- Solenoid monitoring
- Door monitoring

For switching functions see technical data on Page 190

Ordering table

Series	Connection	Guard locking	Switching element	Version	Solenoid operating voltage	
					AC/DC	V
STA	W Cable entry 3 x M20 x 1.5	3 Mechanical	2131 2 NC ⊖ + 1 NC + 1 NO	C1993 Long actuator shaft	103660	STA3A-2131A024MC1993





Safety switch STA-TW with guard locking and guard lock monitoring

- ▶ Actuating heads made of metal
- ▶ Simultaneous monitoring of two safety doors
- ▶ Mechanical release on the front
- ▶ Mechanical key release optional
- ▶ With door monitoring contact



Approach direction



Horizontal and vertical
Can be adjusted in 90° steps

Mechanical release

Is used for releasing the guard locking with the aid of a tool. To protect against tampering, the mechanical release is sealed with sealing lacquer.

Mechanical key release

Additional lock on the switch head. Function as for mechanical release. The mechanical key release setting is indicated in the window. Two keys are included.

Solenoid operating voltage

- ▶ AC/DC 24 V +10%, -15%

LED function display (optional)

A function display (2 LEDs, red and green) is available for the following voltage ranges:

- ▶ AC/DC 24 V +10%, -15%

Guard locking types

STP3 Closed-circuit current principle, guard locking by spring force. Release by applying voltage to the guard locking solenoid.

Switching elements

- ▶ **2131** Slow-action switching contact
2 NC ⊖ + 1 NO + 1 NC
(door monitoring contact)
- ▶ **4121** Slow-action switching contact
2 NC ⊖ + 1 NC / 1 NO
(door monitoring contact)

Cable entry M20 x 1.5

Dimension drawing

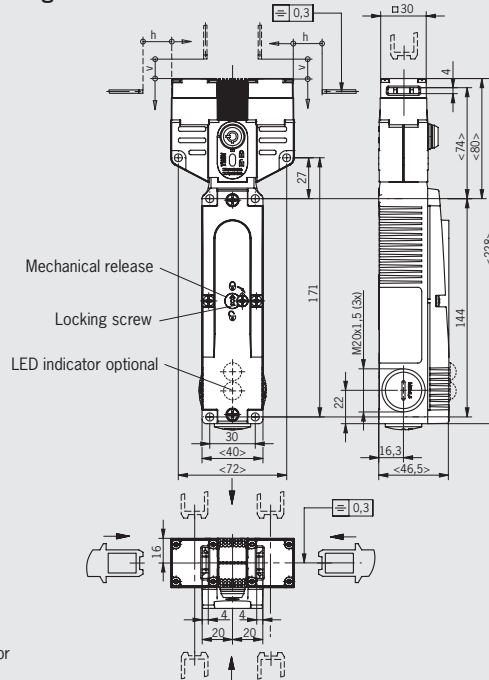

Please order actuator separately
(See Pages 124-126)

For cable glands see page 132

Wiring diagrams Actuator inserted and locked

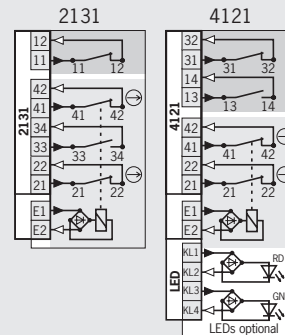

- Solenoid monitoring
- Door monitoring

For switching functions see technical data on Page 192

Ordering table

Series	Connection	Guard locking	Switching element	Version	Solenoid operating voltage	
					AC/DC 24 V	
STA-TW	W Cable entry 3 x M20 x 1.5	3 Mechanical	2131 2 NC ⊖ + 1 NC + 1 NO	With mechanical key release (identical locking)	105617 STA-TW-3A-2131AC024M	
					105888 STA-TW-3A-2131AC024M-S1	
			4121 2 NC ⊖ + 1 NC / 1 NO	024L LED indicator AC/DC 24 V	106545 STA-TW-3A-4121AC024M	
					106379 STA-TW-3A-4121AC024L024M	

Safety switch STA... with guard locking and guard lock monitoring





The technical data on switches, switching elements and guard locking apply to all connections. Further technical data are given for the connection selected.

Reliability values acc. to EN ISO 13849-1

Parameter	Value	Unit
B10d	1.2 x 10 ⁷ operating cycles	

Switch 		Value	Unit
Parameter			
Housing material		Anodized die-cast	
Mechanical life		1 x 10 ⁶ operating cycles	
Ambient temperature		- 20 ... + 80	°C
Weight		Approx. 0.6	kg
Approach speed, max.		20	m/min
Actuating force		35	N
Extraction force (no locked)		30	N
Retention force		20	N
Locking force, max.	Approach direction		
	From top (v)	Side (h)	N
	3000	3000	
Locking force F _{zh} in acc. with GSET-19	Approach direction		
	From top (v)	Side (h)	N
	2300	2300	
Insertion depth (minimum required travel + permissible overtravel)	Actuator S standard	Actuator L for insertion funnel	
Approach direction side (h)	24.5 + 5	28.5 + 5	mm
Approach direction from top (v)	24.5 + 5	28.5 + 5	mm

Switching element 		Value	Unit	
Parameter				
Switching principle		Slow-action switching contact		
Switching element with 4 switching contacts	2131 2 NC ⊕ + 1 NO + 1 NC	4121 2 NC ⊕ + 1 NC + 1 NO	4131 2 NC ⊕ + 2 NO	4141 2 NC ⊕ + 2 NC ⊖
Min. switching current at 24 V DC		1	mA	
Switching voltage, min., at 10 mA		12	V	
Contact material		Silver alloy, gold flashed		

Guard locking 		Value	Unit
Parameter			
Solenoid operating voltage		AC/DC 24 V +10/-15%	
Connection		Reverse polarity protected, integrated bridge rectifier	
Duty cycle		100	%
Power consumption		8	W

Connection, cable entry M20 x 1.5 		Value	Unit
Parameter			
Connection		Screw terminal	
Version		M20 x 1.5	
Conductor cross-section		0.34 ... 1.5	mm ²
Degree of protection according to IEC 60529		IP 67	
Rated insulation voltage U _i		250	V AC/DC
Rated impulse withstand voltage U _{imp}		2.5	kV
Conventional thermal current I _{th}		4	A
Short circuit protection acc. to IEC 60269-1 (control circuit fuse)		4	A gG
Utilization category according to IEC 60947-5-1	AC-15	I _e 4 A U _e 230 V	
	DC-13	I _e 4 A U _e 24 V	

Connection, plug connector SR11



Parameter		Value	Unit
Connection		Plug connector	
Version		SR11 (11-pin + PE)	
Degree of protection according to IEC 60529		IP 65 ¹⁾	
Rated insulation voltage U_i		50	V AC/DC
Rated impulse withstand voltage U_{imp}		1.5	kV
Conventional thermal current I_{th}		4	A
Short circuit protection acc. to IEC 60269-1 (control circuit fuse)		4	A gG
Utilization category according to IEC 60947-5-1	AC-15	I_e 4 A U_e 50 V	
	DC-13	I_e 4 A U_e 24 V	

1) Screwed tight with the related plug connector (see page 128)

Connection, plug connector RC18



Parameter		Value	Unit
Connection		Plug connector	
Version		RC18 (18-pin + PE)	
Degree of protection according to IEC 60529		IP 65 ¹⁾	
Rated insulation voltage U_i		110	V AC/DC
Rated impulse withstand voltage U_{imp}		2.5	kV
Conventional thermal current I_{th}		4	A
Short circuit protection acc. to IEC 60269-1 (control circuit fuse)		4	A gG
Utilization category according to IEC 60947-5-1	AC-15	I_e 4 A U_e 110 V	
	DC-13	I_e 4 A U_e 24 V	

1) Screwed tight with the related plug connector (see Page 129)

Switching functions STA1/STA2 without door monitoring contact

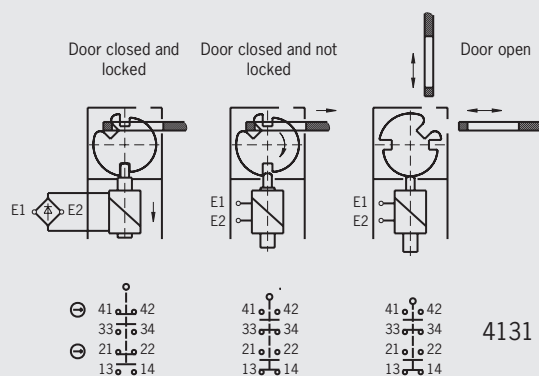

Switching functions STA3/STA4 with door monitoring contact

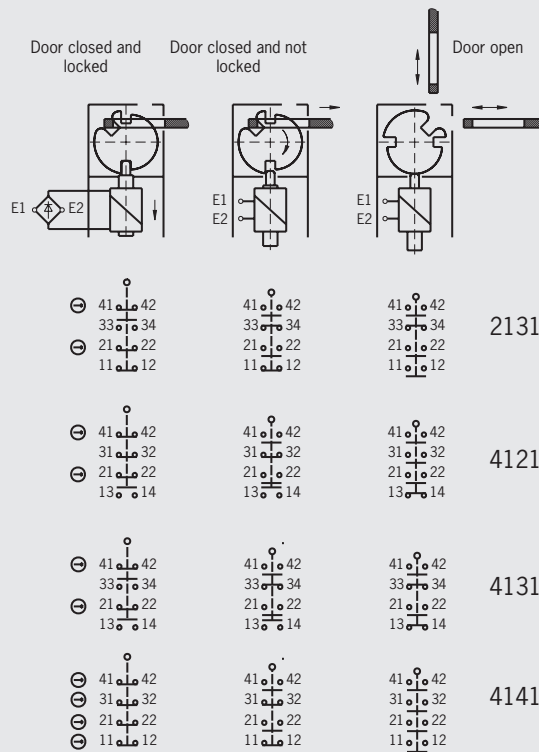

Safety switch STA-TW with guard locking and guard lock monitoring



The technical data on switches, switching elements and guard locking apply to all connections. Further technical data are given for the connection selected.

Reliability values acc. to EN ISO 13849-1

Parameter	Value	Unit
B10d	4.5 x 10 ⁶ operating cycles	

Switch



Parameter	Value	Unit
Housing material	Housing Anodized die-cast	
	Actuating heads Die-cast aluminum	
	Cam in actuating head Stainless steel	
Mechanical life	1 x 10 ⁶ operating cycles	
Ambient temperature	- 20 ... + 55	°C
Weight	Approx. 0.62	kg
Approach speed, max.	20	m/min
Actuating force	35	N
Extraction force (no locked)	30	N
Retention force	20	N
Locking force, max.	Approach direction	
	From top (v)	Side (h)
	2500	2500
Locking force F _{zh} in acc. with GS-ET-19	Approach direction	
	From top (v)	Side (h)
	2000	2000
Insertion depth (minimum required travel + permissible overtravel)	Actuator S standard	
Approach direction side (h)	24.5 + 5	mm
Approach direction from top (v)	24.5 + 5	mm

Switching element



Parameter	Value	Unit
Switching principle	Slow-action switching contact	
Switching element with 4 switching contacts	2131 2 NC ⊕ + 1 NO + 1 NC	4121 2 NC ⊕ + 1 NC + 1 NO
Min. switching current at 24 V DC	1	mA
Switching voltage, min., at 10 mA	12	V
Contact material	Silver alloy, gold flashed	

Guard locking



Parameter	Value	Unit
Solenoid operating voltage	AC/DC 24 V +10/-15%	
Connection	Reverse polarity protected, integrated bridge rectifier	
Duty cycle	100	%
Power consumption	8	W

Connection, cable entry M20 x 1.5



Parameter	Value	Unit
Connection	Screw terminal	
Version	M20 x 1.5	
Conductor cross-section	0.34 ... 1.5	mm ²
Degree of protection according to IEC 60529	IP 67	
Rated insulation voltage U _i	250	V AC/DC
Rated impulse withstand voltage U _{imp}	2.5	kV
Conventional thermal current I _{th}	4	A
Short circuit protection acc. to IEC 60269-1 (control circuit fuse)	4	A gG
Utilization category according to IEC 60947-5-1	AC-15	I _e 4 A U _e 230 V
	DC-13	I _e 4 A U _e 24 V

Switching functions STA-TW

