

# SERIES HS60

NorthStar™ brand

## Hollowshaft Encoder

### Key Features

- Industry-Leading 2-7/8" Hollowshaft Capability
- Multi-Stage Sealing for Wash-Down Applications
- Stainless Steel Shaft for Corrosion Resistance
- Dual-Split Clamping Collar for Positive Shaft Engagement
- Oversized Bearings for Long Service Life
- Magnetic Sensor Technology and Encapsulated Electronics Resist Moisture and Contamination

HD  
Heavy Duty

CE  
EN 61326-1

RoHS



## SPECIFICATIONS

### STANDARD OPERATING CHARACTERISTICS

**Code:** Incremental, Magnetic  
**Pulses per Revolution:** 64-1024 PPR  
**Phasing Sense:** A leads B for Counter-Clockwise rotation (CCW) viewing encoder-mounted end  
**Quadrature Phasing:** 90° ± 22°  
**Symmetry:** 180° ± 54°  
**Index:** Once per revolution  
**Number of Output Modules:** Single or Dual

### ELECTRICAL

**Input Voltage Requirement:** 5-15 or 5-26 Volts DC  
**Current Requirement:**  
 With Electrical Option L: 45 mA typical per sensor module plus line driver load  
 With Electrical Option V or 5: 65 mA typical per sensor module plus line driver load  
**Output Signals:**  
 4428 Differential Line Driver: 150mA, sink or source  
 IC-WE Differential Line Driver: 150mA, sink or source  
**Frequency Response:** 0 - 120kHz Data & Index  
**Noise Immunity:** Tested to EN61326-1  
**Electrical Immunity:** Reverse polarity and short circuit protected  
**Connector:** 10 pin industrial duty latching, sealed NEMA 4 & 12, IP65; MS connector or pig-tail

### MECHANICAL

**Bore Diameter:** 1-1/8" to 2-7/8"  
**Mounting Configuration:** Hollow Shaft mount with Anti-Rotation Tether  
**Shaft Speed:** Labyrinth Shaft Seal: 3,600 RPM; V-Ring Shaft Seal: 1,000 RPM  
**Shaft Length Required:** 2.36" min  
**Acceleration Rate:** 3,600 rpm/sec max  
**Allowable Shaft End-Play:** ± 0.150" (tether limit)  
**Allowable Shaft Runout:** 0.015" TIR typical (rpm dependent)  
**Housing Material:** Hard Anodized Aluminum W/Stainless Steel Hub  
**Weight:** 14.7 lbs

### ENVIRONMENTAL

**Operating Temperature Range:** -20°C to +80°C  
**Storage Temperature Range:** -40°C to +120°C  
**Shock (Sensor Module):** 30 G's Min  
**Vibration:** 18 G's @ 5-2000 Hz spectrum  
**Humidity:** Up to 98% (non-condensing)

### ELECTRICAL CONNECTIONS

Signal	Connector Pin	Pigtail Cable	MS 3102E18-IT#
Common	1	Black	F
B	2	Green	B
A	3	Blue	A
Z*	4	Violet	C
No Connection	5	—	E
Vcc +	6	Red	D
B	7	Yellow	I
A	8	Gray	H
Z*	9	Orange	J
Shield	10	Braid	G

\* Index (Z) optional. See Ordering Information

**Ordering Information**

To order, complete the model number with code numbers from the table below:

Code 1: Model	Code 2: PPR	Code 3: Index	Code 4: Wheel Bore	Code 5: Termination	Code 6: Electrical	Code 7: Seal
<input type="checkbox"/> 6	<input type="checkbox"/> <input type="checkbox"/> <input type="checkbox"/> <input type="checkbox"/>	<input type="checkbox"/>	<input type="checkbox"/> <input type="checkbox"/> <input type="checkbox"/>	<input type="checkbox"/>	<input type="checkbox"/>	<input type="checkbox"/>
Ordering Information						
<b>H6 HS60</b> Hollowshaft, Single Output	<b>0064</b>	<b>L</b> No index	<b>T01</b> 1-1/8"	<b>M45</b> 45 mm	<b>C</b> Latching Industrial Connector with 1/2" NPT	<b>L</b> 5-15VDC In, 5-15V Line Driver (4428) Out
	<b>0128</b>	Available When Code 2 is 0512 or 1024	<b>T02</b> 1-3/8"	<b>M50</b> 50 mm		
<b>0256</b>	<b>T03</b> 1-5/8"		<b>M55</b> 55 mm	<b>M</b> 10 Pin MS Connector	<b>5</b> 5-15VDC In, 5V Line Driver (4428) Out	
<b>0512</b>	<b>T04</b> 1-7/8"	Additional Bore Sizes Available, Please Consult Factory	<b>T05</b> 2.00"			<b>P</b> 18" Pigtail Cable
<b>1024</b>	<b>T06</b> 2-1/8"		<b>T07</b> 2-1/4"	<b>Q</b> Latching Industrial Connector on 18" Pigtail Cable		
<b>D6</b> Hollowshaft, Dual Output	<b>G</b> With Gated, Differential Index		<b>T08</b> 2-3/8"		<b>T09</b> 2-1/2"	<b>R</b> Latching Industrial Connector on 18" Pigtail Cable without Mating Connector
	<b>Z</b> With Differential Index		<b>T10</b> 2-7/8"			

**Note:** See ACCESSORIES Section For Connectors, Spare Parts and Pulse Wheels

**DIMENSIONS** inch [mm]

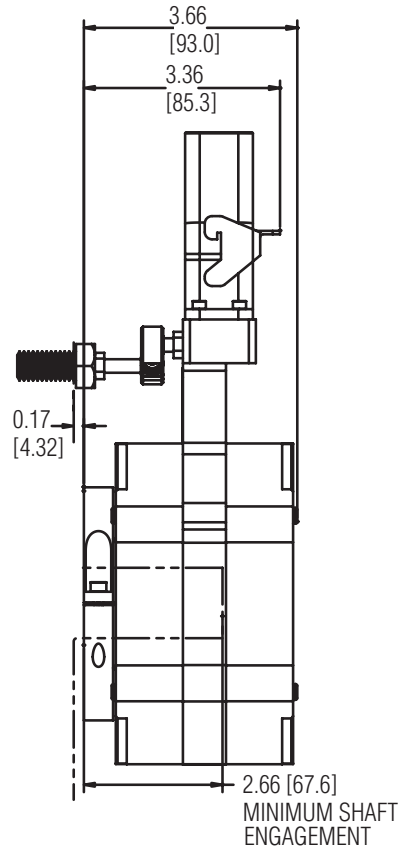
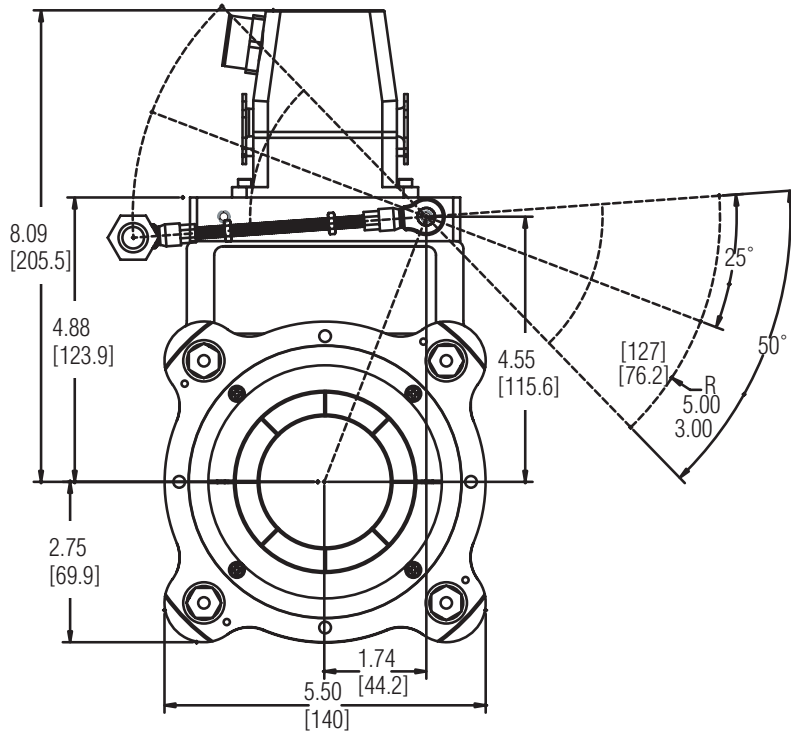

Worldwide Brands: NorthStar™ • Dynapar™ • Hengstler™ • Harowe™

**DYNAPAR**  
INNOVATION - CUSTOMIZATION - DELIVERY

[WWW.DYNAPAR.COM](http://WWW.DYNAPAR.COM)

Headquarters: 1675 Delany Road • Gurnee, IL 60031-1282 • USA

**Customer Service:**  
Tel.: +1.800.873.8731  
Fax: +1.847.662.4150  
custserv@dynapar.com

**Technical Support**  
Tel.: +1.800.234.8731  
Fax: +1.847.662.4150  
northstar.techsupport@dynapar.com

**European Sales Representative**  
Hengstler GmbH  
Uhlandstrasse 49, 78554 Aldingen  
Germany  
[www.hengstler.com](http://www.hengstler.com)

NorthStar™ brand is a trademark of DYNAPAR. All rights reserved.  
Specifications subject to change without notice.  
Document No. 702908-0002, Rev. C ©2017 DYNAPAR